

# **GTD**

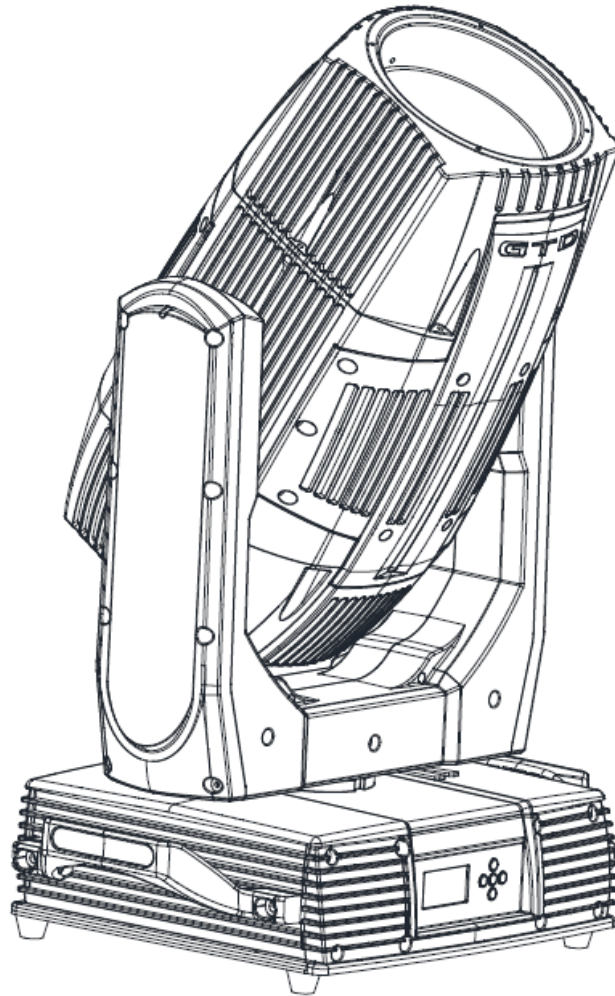

**GTD-F4 II BEAM**  
**461W II Moving Head**  
**User Manual**

GTD all rights reserved. Information, specifications, diagrams, images, and instructions herein are subject to change without notice. GTD logo and identifying product names and numbers herein are trademarks of GTD. Copyright protection claimed includes all forms and matters of copyrightable materials and information now allowed by statutory or judicial law or hereinafter granted. Product names used in this document may be trademarks or registered trademarks of their respective companies and are hereby acknowledged. All non-GTD brands and product names are trademarks or registered trademarks of their respective companies.

GTD and all affiliated companies hereby disclaim any and all liabilities for property, equipment, building, and electrical damages, injuries to any persons, and direct or indirect economic loss associated with the use or reliance of any information contained within this document, and/or as a result of the improper, unsafe, insufficient and negligent assembly, installation, rigging, and operation of this product.

Guangzhou GTD Culture & Technology Group Co.,Ltd. | 27 Fu Yuan Yi Road, Guangzhou 510805, P.R.China  
+86-20-61808296 | +86-20-61812282 fax | [www.gtd-lighting.com](http://www.gtd-lighting.com) | [contact@gtd-lighting.co](mailto:contact@gtd-lighting.co)

---

P/N : 150201XXXX

# Table of contents

<b>1. Safety instructions</b> .....	<b>1</b>
<b>2. Product introductions</b> .....	<b>3</b>
2.1 Dimensions.....	3
2.2 Fixture overview.....	4
2.3 Accessories.....	4
<b>3. Packing and shipping</b> .....	<b>5</b>
3.1 Protection lock.....	5
3.2 Unpacking.....	5
3.3 Packing after use.....	5
<b>4. Installation</b> .....	<b>6</b>
4.1 Clamps installation.....	6
4.2 Device installation.....	6
4.3 Lamp fitting and adjustment.....	7
<b>5. Power / Control connection</b> .....	<b>8</b>
5.1 Power connection.....	8
5.2 Control connection.....	8
5.3 Testing.....	8
<b>6. Control panel</b> .....	<b>9</b>
6.1 Panel instruction.....	9
<b>7. Technical specification</b> .....	<b>10</b>
<b>8. Gobos and colors</b> .....	<b>12</b>
8.1 Gobo specification.....	12
8.2 Gobos.....	12
8.3 Colors.....	13
<b>9. Menu structure</b> .....	<b>14</b>
<b>10. DMX protocol</b> .....	<b>16</b>
<b>11. System wiring diagram</b> .....	<b>20</b>
<b>12. Maintenance and Troubleshooting</b> .....	<b>21</b>
12.1 Cleaning and maintenance.....	21
12.2 Troubleshooting.....	21
<b>13. Spare parts list</b> .....	<b>25</b>

# 1. Safety instructions

Before using the fixture, read the latest version of the product user manual, paying particular attention to the safety instructions. Please check [www.gtd-lighting.com](http://www.gtd-lighting.com) for the latest revision/update of the user manual.



The manufacture of this fixture, are not responsible for damages, resulting from misuse of this fixture, due to the disregard of the information printed in this user manual.



**DANGER!**  
Hazardous voltage. Risk of lethal or severe electric shock



**WARNING!**  
Wear protective eyewear. Never look directly into the light source.



**WARNING!**  
Burn hazard. Hot surface. Do not touch.



Only to direct mounting on non-combustible surfaces.



Replace all cracked glass shields.

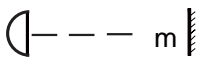

Minimum distance to lighted objects.

$t_a \dots ^\circ\text{C}$  Maximum ambient temperature.

$t_c \dots ^\circ\text{C}$  Maximum temp of the external surface.

**General guidelines** ⚠

- This product has a protection rating of IP66.
- Never open this fixture while in use.
- The fixture should be kept clean. DO NOT operate the fixture in extreme heat or dusty environments. Avoid contact with chemical liquid.
- Minimum distance to lighted objects must be 49.21feet (15m).
- Maximum temp of the external surface 248°F (120°C).
- Maximum ambient temperature 113°F (45°C).
- Minimum distance of inflammable materials from the surface 1.6 feet (0.5m).
- Lamp should be changed if damaged or distorted in shape due to extreme heat.
- Cover, prism or LCD Menu Function Display with visible damages such as cracks or scratches must be replaced to ensure performance of the fixture.
- Disconnect the fixture from power before changing any parts or accessories.
- Basic insulation should be maintained between the controllable device and the product power supply.
- Make sure that the installation area can hold a minimum point load of 10 times the weight of all installed fixtures, clamps, cables, auxiliary equipment, etc. Check that the cover, clamps and locks are undamaged. Certified safety cables must always be used when installing the fixture.
- The fixture is only intended for installation, operation and maintenance by qualified professional. Instructions stated in the manual must be complied.
- The fixture must be kept in a well-ventilated place at least 50 cm away from any wall surface. Check if the fans or ventilation openings are unblocked.
- This fixture uses discharge lamp. To avoid reducing the lamp's life, wait at least 15 minutes after powering off to allow the unit to cool down before handling.
- Broken or damaged cables and light source can only be fixed or changed by certified technicians, certified local distributors or the manufacturer to ensure operational safety.
- Do not stick filters or other materials onto the lens. Do not modify the fixture or install other than GTD manufactured parts.
- For questions regarding safety operation, please contact our technical personnel or call the service hotline +8620 61808296.

## 2. Production instructions

### 2.1 Dimensions

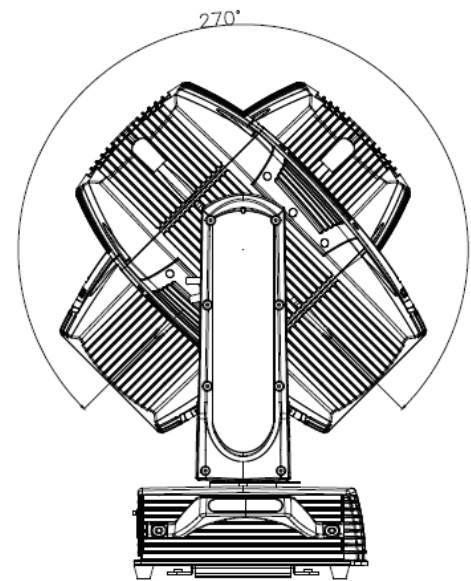
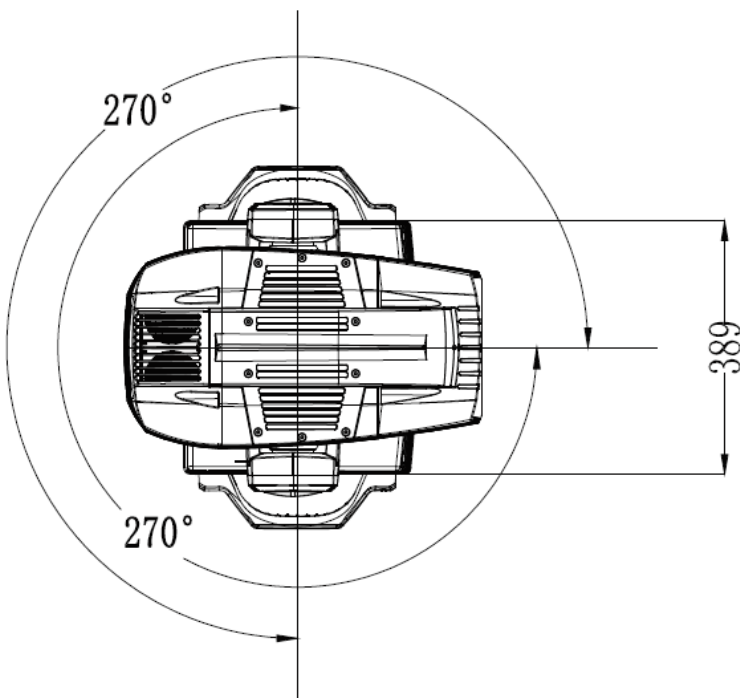
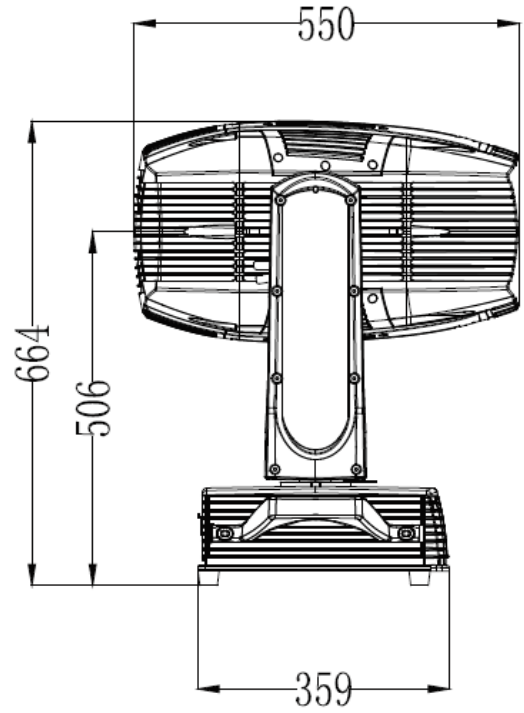
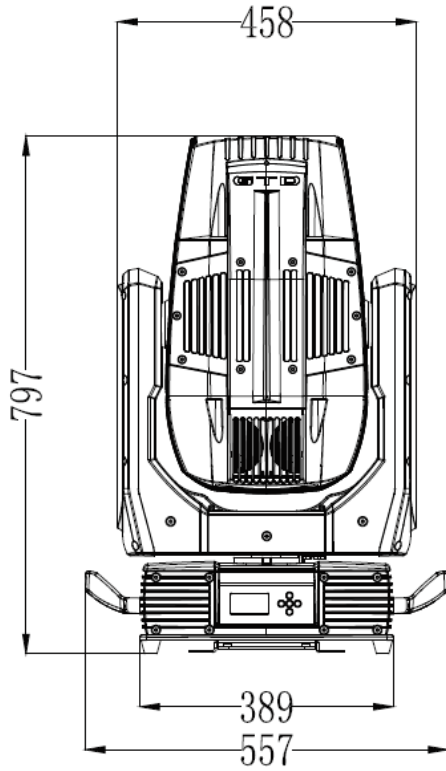

2.2 Fixture overview

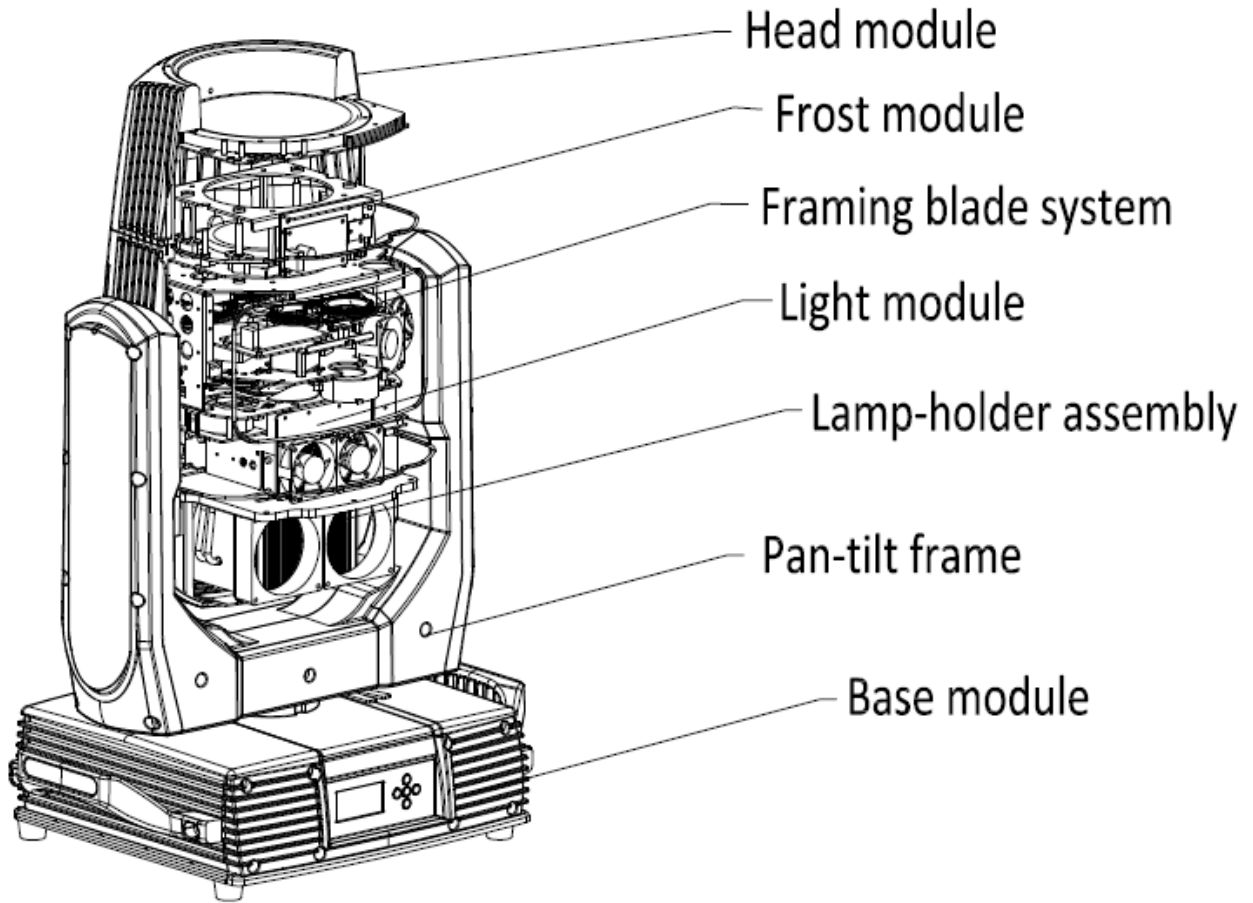

2.3 Accessories

Item	Qty	Unit	Remark
User Manual	1	Pc	--
Clamps	2	Set	02A+21A 42-52mm Load weight 200KG
Safety cable	1	Pc	Φ4*60cm 7*19 pc with hook Material : Steel
3-pins signal line	1	Set	--
Power cable	1	Set	1.2*2.5mm <sup>2</sup> Diameter 3.9

## 3. Packing and shipping

### 3.1 Protection lock

Pan and tilt locks are equipped to ensure safe transportation.

PAN: 4 lock positions are located evenly on the Pan.

TILT: 5 lock positions are located on left and right side of the Tilt with the third one in the center.

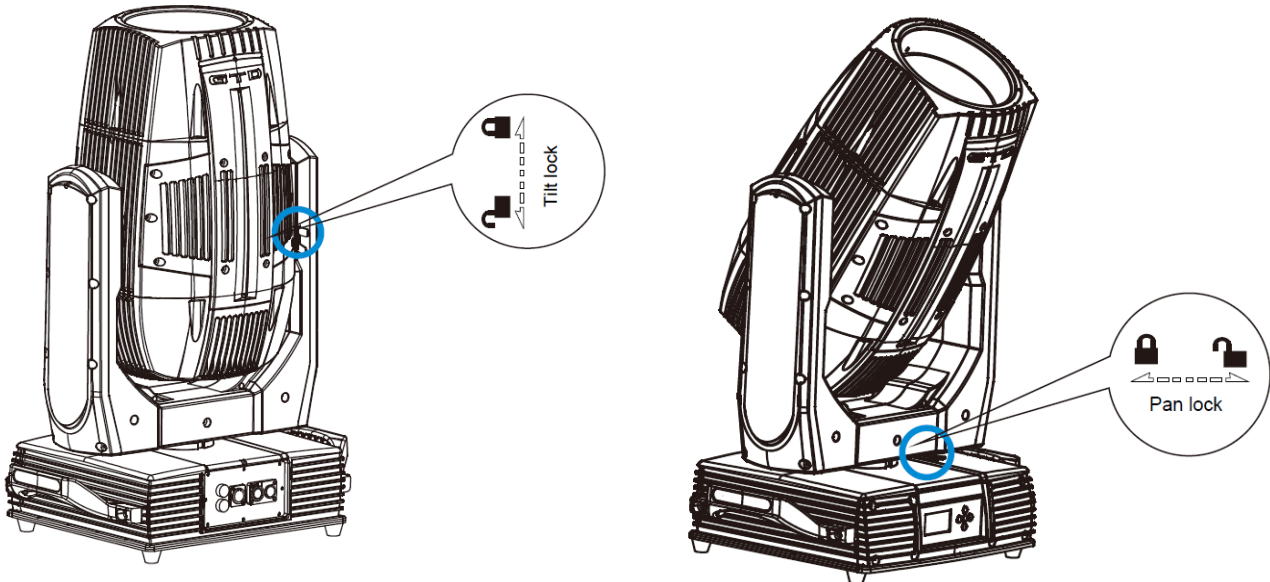

### 3.2 Unpacking

#### ⚠ Notes

All products are quality controlled and checked for any faults before they are dispatched to customers. If the fixture is damaged during delivery, the customer must notify the shipper and manufacturer to file a damage insurance claim. Photographic evidence of the damage must be provided.

**Flight-Case :** Open the cover of the flight-case and remove the plastic packing bags. Hold the handles of the fixture firmly and take it out carefully.

**Cardboard box :** Open the box and take out the whole set of packaging foam which contains both the fixture and its accessories. Remove the foam from the top, put away the accessories, and then take out the fixture wrapped in the plastic bag.

#### ⚠ Notes

Check if the pan and tilt are unlocked before connecting the fixture to power.

### 3.3 Packing after use

1. Switch off the fixture and wait for at least 5 minutes before disconnecting it from AC power. Cool down the fixture for at least 15 minutes before packing.
2. Lock pan and tilt.
3. Flight case: Wrap the fixture in plastic bags. Hold it by the handles, and then carefully place it inside the flight case along with all the accessories. Close the cover. Only 3 layers are allowed when piling up the flight cases. Do not upside down.
4. Cardboard box: Wrap the fixture in plastic bags. Put it in the packaging foam along with all the accessories. Place the other set of packaging foam on top then carefully put it inside the cardboard box.



## 4. Installation

### 4.1 Clamps installation

The fixture can be placed on the stage or mounted on the truss facing any direction. Attach the clamps to the mounting position on the base of the fixture.

**Warning :** Use two clamps when mounting the fixture. Turn the screws attached to each clamp a 1/4 turn clockwise to lock. Always remember to use the safety cable which goes through the mounting hole on the base. Do not attach the safety cable on the handle.

### 4.2 Device installation

1. Make sure there is no damage on the clamps or safety cables before installation.
2. The clamp is mounted on the chassis of the fixture. Horizontally insert the clamp into the mounting holes of the chassis. Fasten the clamp tightly by a 1/4 turn clockwise. Fix another clamp in the same way.
3. Check if pan and tilt are unlocked before connecting the unit to AC power.

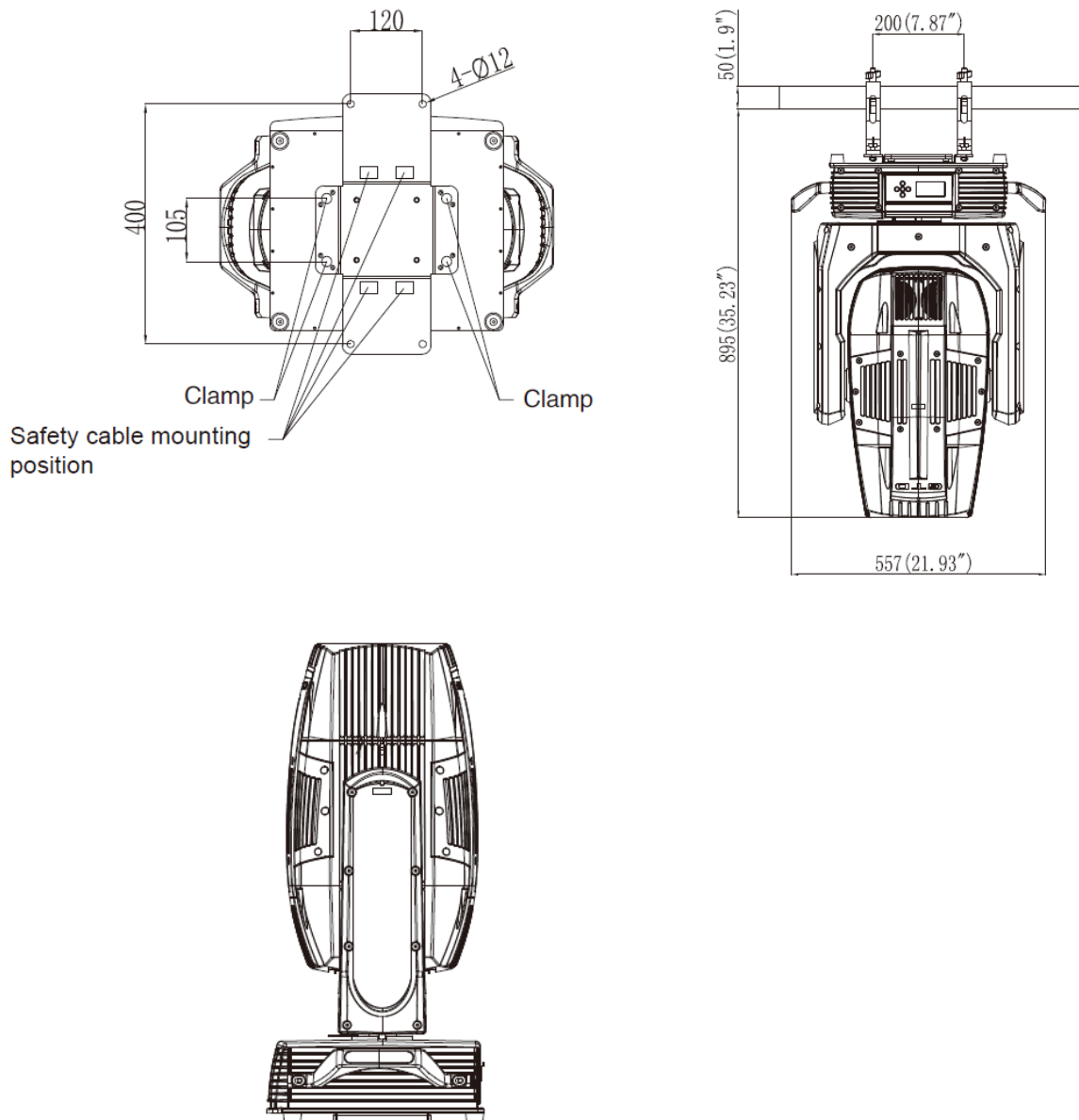

### 4.3 Lamp fitting and adjustment

1. Disconnect the fixture from AC power. Cool down the fixture. Set the Tilt lock in a horizontal position.
2. Remove the lamp holder lower cover and plug out the waterproof terminal when disassemble the bulb, then loosen the fixed plate and take out the bulb.
3. Put the bulb into the fixed plate, then press the bulb clockwise with the fixed plate when install the bulb, observe the bulb spot and adjust it after lighted the bulb. Finally, plug in the waterproof fan and lamp holder lower cover.

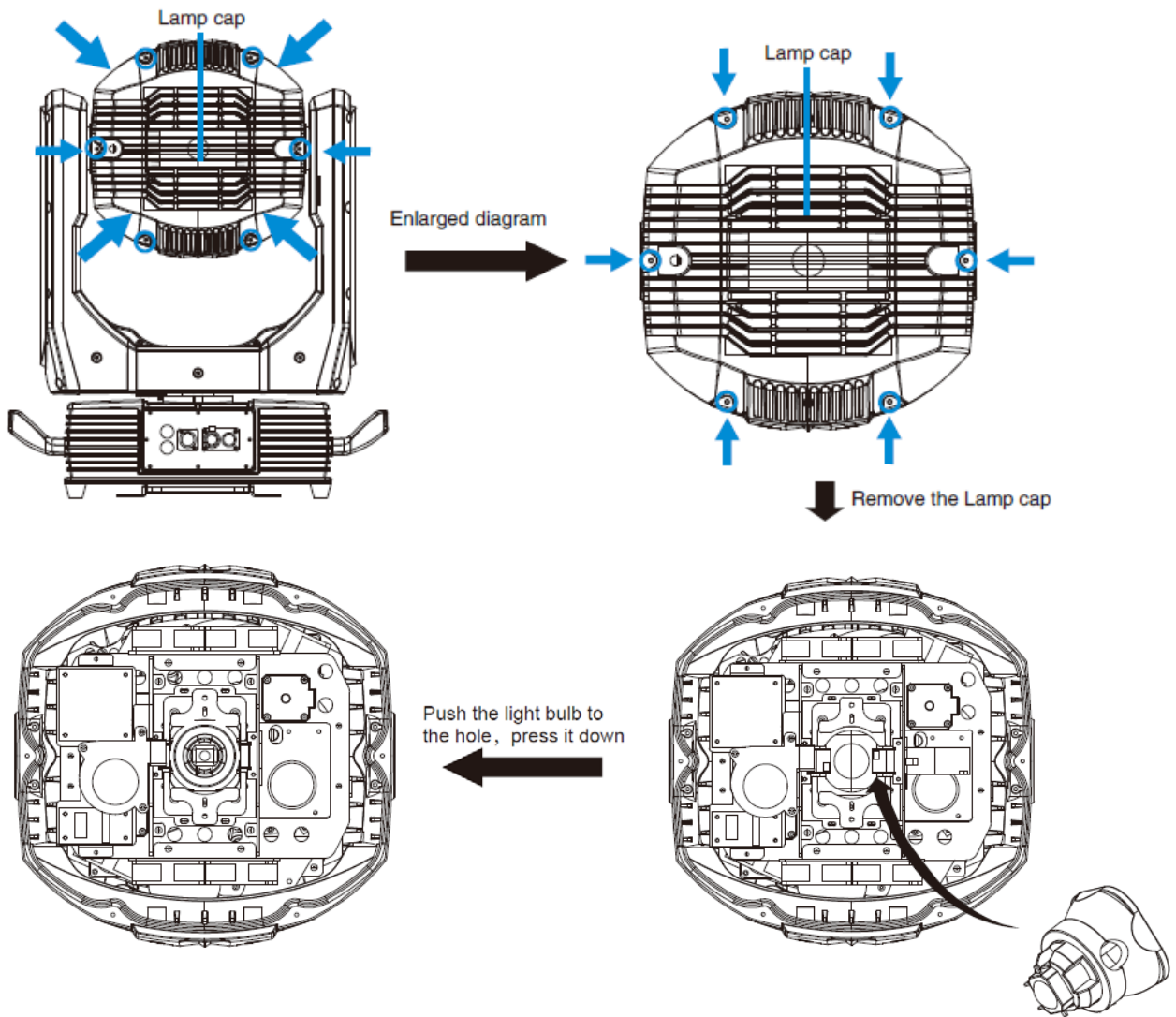

**⚠ Note**

The fixture is equipped with OSRAM SIRIUS HRI 461W, which is featured with high efficiency and short-arc characteristic, such as a stable 7500K color-temperature and average lifespan of 1500h.

**⚠ Note**

1. Fitting another type of lamp will cause potential damage to the fixture. Change the lamp before it reaches its lifespan. Read the guidelines in the package carefully when fixing the lamp.
2. To avoid any impact on the beam, do not touch the bulb with your bare hands. The lamp must be kept clean with the use of the clean paper contained in its package.

## 5. Power/ Control connection

### 5.1 Power connection

Connection method:

- L (Live) Brown wire
- E (Earth) Yellow / Green bi-color wire
- N (Neutral) Blue wire
- The voltage and frequency of the power source must be in compliance with the ones marked on the fixture. It is strongly recommended that each fixture are to be connected to the power source separately so that they can be switched on / off individually.

### 5.2 Control connection

The fixture has 3-pin XLR connectors for DMX data input and output as shown below. Connection between the console and fixture, and between fixtures must be made with 2 core screened DMX signal cable. Maximum connecting distance of signal cable is 150 meters. Additional DMX512 signal-amplifier is recommended for longer distance

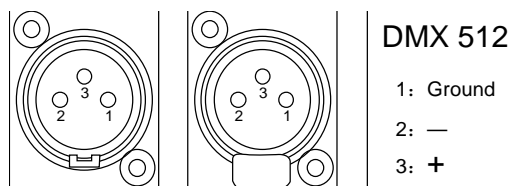

Connect the Console’s DMX OUTPUT to the first fixture’s DMX INPUT, then the first fixture’s DMX OUTPUT to the second fixture’s DMX INPUT and so on. It is recommended not to connect more than 32 units on a single DMX universe. On the last fixture’s output connect a DMX terminator. (The terminator is a 3-pin XLR connector with a 1/4W and 120Ω resistor between the pin 2 and pin 3) as shown below:

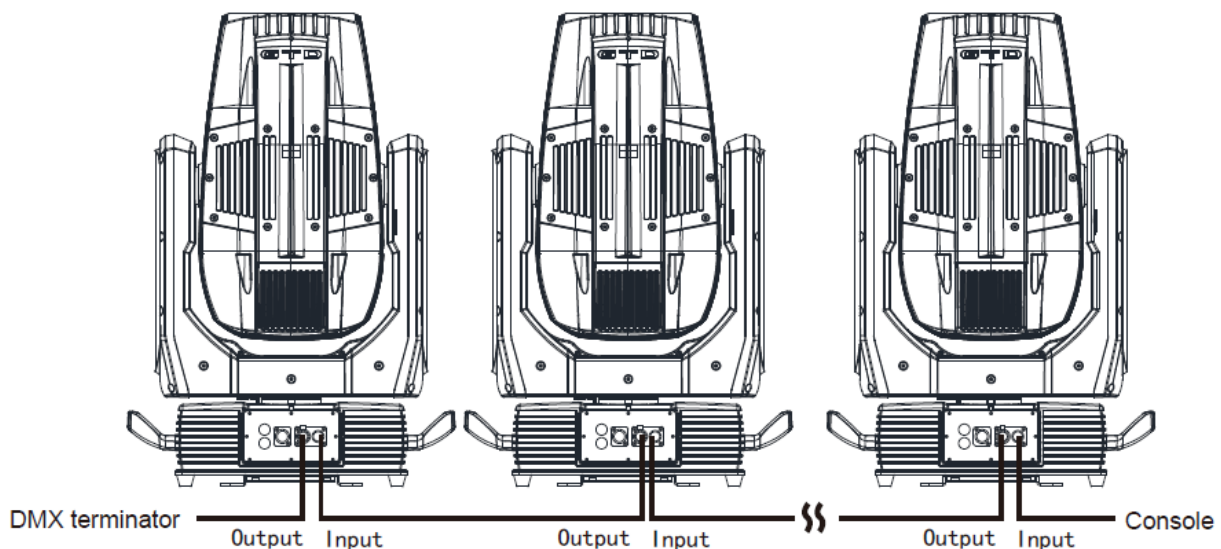

### 5.3 Testing

Connect the fixture to AC power. Check if the lamp is on and the fixture is independently controllable before putting into operation.

## 6. Control panel

### 6.1 Panel instruction

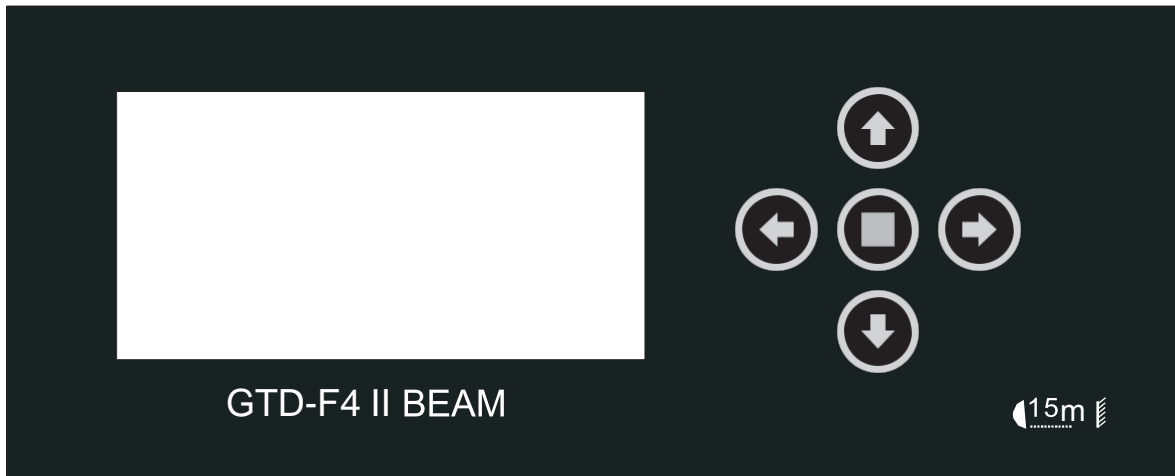

- The control panel features touch-sensitive buttons and LCD digital display for quick and easy setup of address code and functions menu.
- Press UP or DOWN to view or select the function menu.
- Press CENTER to choose a function and enter into corresponding sub menu. Each menu represents a specific function of the fixture.
- Press RIGHT to select the specific function and save the changes or enter into the submenu, then press UP or DOWN to change the value of the selected function (increase or decrease).
- Press RIGHT to return to the previous menu or exit.
- Button panel indicator:

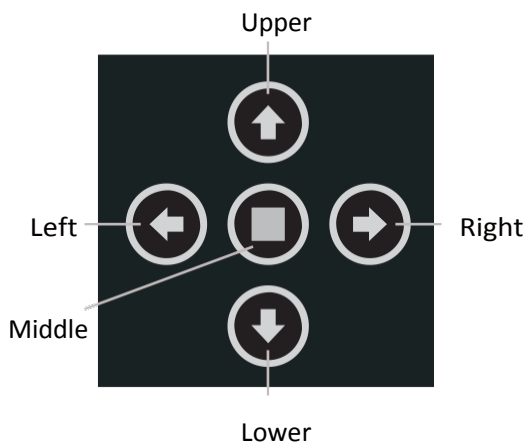

## 7. Technical specification

- **Optical**

Light source: OSRAM SIRIUS HRI 461W

Expected average lifetime: 1500 h

Color temperature correction: 7500K

Zoom: 0° ~ 1.9°

CRI : Ra 78

Focus: High-precision glass lenses, electronic linear HD focus

Prism: 1 pc tip 8-facet prism, 1 pc flat 8-facet prism, 1 pc spherical-surface prism, 1 pc 4-facet gradient prism, 1 pc unilateral row prisms, prisms can be controlled independently, or can be combined to make abundant beam effects.

Frost: 1-independent frost effect

- **Gobo**

Rotating gobo wheel: 8 interchangeable gobos + open, indexing, CW/CCW rotation, variable speed

Fixed gobo wheel: 9 gobos + open, CW/CCW rotation, variable speed

Gobo outside diameter: 18mm

Max. Image diameter: 7mm

Max. Thickness: 0.5mm

Gobo material: metal

- **Color**

Color wheel: 14 colors + open, split color, CW/CCW rotation, “Rainbow effect” in both directions

- **Electrical**

Power input, nominal: AC 100-240V 50/60Hz

Max. Power consumption: 680W, max current: 7.1A, PF: 0.9

Power supply unit: Auto-ranging electronic SMPS

Main fuse: 250V/10A

Ballast: Electronic

Power input: Self-contained power cord

DMX data input/output: Chassis 3-pin (in/out)

- **Control and programming**

Control channels (DMX): 19/17/22

Protocol: DMX-512 RDM

Display: OLED

- **Physical / Installation**

Weight: 44Kg (97lbs.)

IP rating: IP66

Material: Aluminum, steel, plastic

Mounting points: Four quarter-turn locking points + attachment points for safety wire

● **Dynamic effects**

Pan/Tilt movement: 540°/270°

Iris: Motorized adjustable iris, wide range of variable pulse effects

Strobe: 1-25Hz, synchronized, pulse effects

Dimmer: 0-100%, mechanical dimming

● **Thermal**

Operating range: 5°F to 113°F (-15°C to +45°C)

Startup range: -13°F to 113°F (-25°C to +45°C)

Storage range: -40°F to 140°F (-40°C to +60°C)

Cooling: Active fan

● **Certification and Safety**

**EMC:** EN 55103-1:2009, EN 55103-2:2009, EN 61000-3-2:2006+A2:2009, EN 61000-3-3:2013,  
GB/T 17743-2007, GB 17625.1-2012

**Safety:** EN 60598-2-17:1989/A2:1991, GB 7000.1-2015, GB 7000.217-200811

● **Photometric**

**GTD-F4 II BEAM**

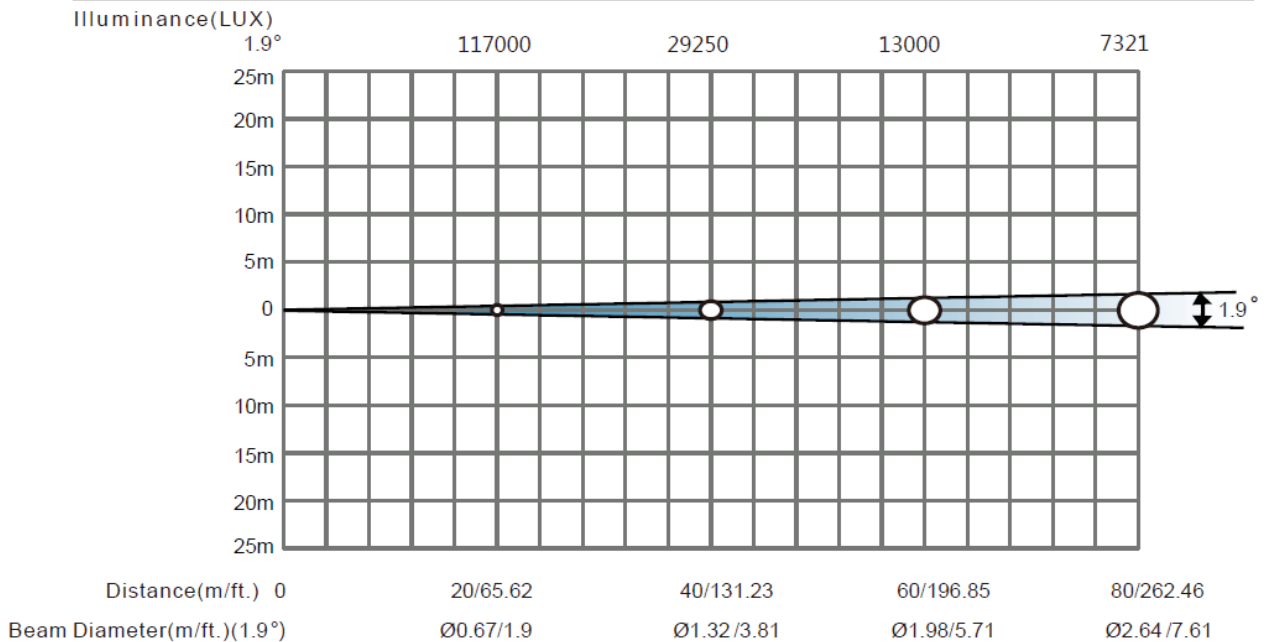

● **Other teatures**

- Enhanced stability of the fixture due to the wide input voltage AC/DC switching power supply which both reduces the impact of power and voltage fluctuations, and removes the restriction of voltage and frequency variations in different countries.

- Automatic energy saving: when the shutter or CMY is closed, power consumption will be reduced automatically with the photoelectric tracking induction technology.
- Sleep mode: uses the most advanced technology to remotely activate sleep mode. When the fixture is disconnected from signal, the sleep mode is enabled automatically to make it more stable and safer. Sleep time can be customized.
- Power setting: built-in continuous rechargeable battery, allowing setting functional data via LCD interface without power connection

## 8. Gobos and colors

### 8.1 Gobo specification

All patterns are made onto the metal gobos, and can be customized according to user's requirement.

The customized size is as below:

Gobo material	Outer dimension	Effective dimension	Thickness
Glass gobo	Φ18mm	Φ7mm	0.5mm
Gobo material: metal			

### 8.2 Gobos

One rotating gobo wheel: 8 interchangeable gobos + open, indexing, CW/CCW rotation, variable speed

One fixed gobo wheel: 9 gobos + open, CW/CCW rotation, variable speed

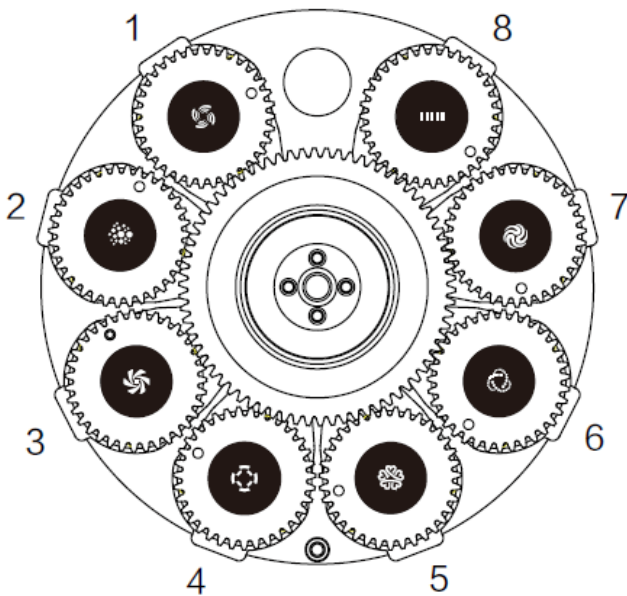

Rotating gobo wheel

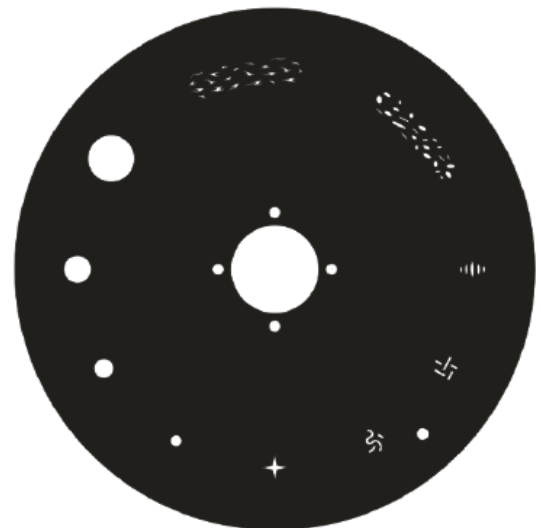

Fixed gobo wheel

**8.3 Colors**

Color wheel: 14 colors + open, split color, CW/CCW rotation, "Rainbow effect" in both direction

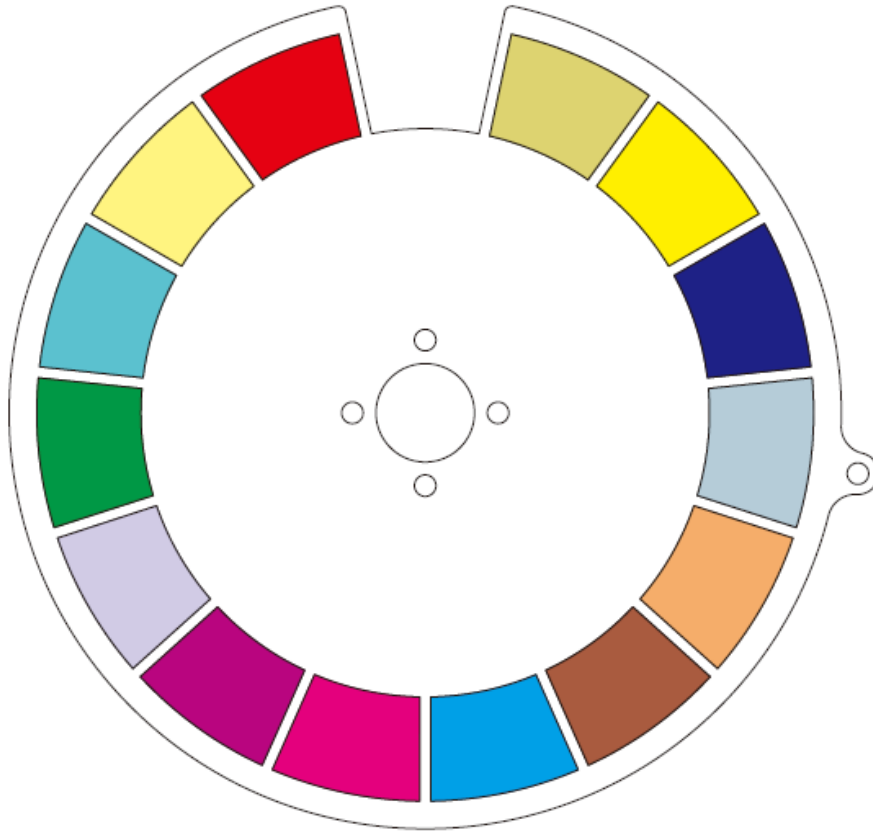

1. Red	2. Light yellow	3. Blue Green	4. Green	5. Light Blue -purple	6. Purplish red
7. Rose red	8. Blue	9. Brown	10. Light brown	11. Cool color	12. Fluorescence
13. Deep yellow	14. Yellow green				



## 9. Menu structure

Run setting	Address Setting	Address 001~ XXX		Setting the DMX address
	Value Display	strobe.....		Display the channel value
	Auto-Program	Master /Slave		Run auto program in master or slave
Device Info	Time Info	Total Time	XXXX H	Product total run time
		Last Time	XX:XX	Last product run time
		Last Time Code	XXX	Clear last time password
		Bulb time	XXXX H	Camp life
		Lamp Time Code	XXX	Clear lamp time password
	Temperature	Temperature 1   XXX /°F Temperature 2   XXX /°F		
	Fan information	Head Fan 1       XXXXX rpm Head Fan 2       XXXXX rpm Head fan 3       XXXXX rpm Head fan 4       XXXXX rpm		
	False information			
	Software Version	Firmware version Software version Hardware version	Equipment Control System Information	
Lamp Control	Lamp On/Off	On/Off		Open lamp
	Power On Lamp On	Enable/Disable		Power on open lamp
	Console Lamp On	Enable/Disable		Console open lamp
	Lamp On Temp.	20~79,45°C /68~174 ,	113°F	Open lamp below
	Lamp Off Temp.	80~139, 120°C/176~282,	266°F	Close lamp above
System Setting	Status Setting	Console Set Addr	Enable/Disable	Address can be changed by
		No Signal Status	Off/Hold/Auto/Music	The status while no signal
		Pan Reverse	Enable/Disable	Pan Reverse
		Tilt Reverse	Enable/Disable	Tilt Reverse
		Scan auto reset	Enable/Disable	Automatic reset after manual scan
	Fan Speed	Smart Control High Speed Low Speed	Auto fans speed Fans high speed Fans low speed	
	Display Setting	Backlight Time	1~60 Min/Disable, 1M	Backlight off time
		Key Lock	Enable/Disable	Press <menu> 3s to unlock
		Disp Rev	Auto/Positive/reverse	
		Language	English/Chinese	Change the language
	Temperature Unit	Celsius Fahrenheit		Temperature unit
	Restore Default	Restore/Cancel		Restore to default value

Reset	System Reset Scan Reset Color Reset Gobo Reset Strobe Reset Others Reset			System reset Pan an tilt motor reset All color motor reset All gobo motor reset All strobe motor reset All other motor reset
Channel Adjust	Test Mode	Strobe.....		
	Manual Mode	Strobe.....	Strobe = XXX :	Manual control
	Adjust Mode	Password	Password = XXX	The password of adjust mode Fixed all begin position
Channel Mode	Channel mode selection	Standard Mode/Basic Mode/Extended Mode		Standard Mode Basic Mode Extended Mode

## 10. DMX Protocol

DMX mode			Name	DMX value		DMX percentage		Function
Standard	Basic	Extended						
1	1	1	Strobe/Shutter	0	31	0.0%	12.2%	Close
				32	63	12.5%	24.7%	Shutter open
				64	95	25.1%	37.3%	Strobe, slow→ fast
				96	127	37.6%	49.8%	Shutter open
				128	159	50.2%	62.4%	Random strobe , slow→ fast
				160	191	62.7%	74.9%	Shutter open
				192	223	75.3%	87.5%	Random strobe ,slow→ fast
				224	255	87.8%	100.0%	Shutter open
2	2	2	Intensity	0	255	0.0%	100.0%	From 0 to 100%
		3	Intensity 16Bit	0	255	0.0%	100.0%	Intensity fade, fine (LSB)
3	3	4	Color1 wheel	0	7	0.0%	2.7%	Open
				8	15	3.1%	5.9%	Color 1
				16	23	6.3%	9.0%	Color 2
				24	31	9.4%	12.2%	Color 3
				32	39	12.5%	15.3%	Color 4
				40	47	15.7%	18.4%	Color 5
				48	55	18.8%	21.6%	Color 6
				56	63	22.0%	24.7%	Color 7
				64	71	25.1%	27.8%	Color 8
				72	79	28.2%	31.0%	Color 9
				80	87	31.4%	34.1%	Color 10
				88	95	34.5%	37.3%	Color 11
				96	103	37.6%	40.4%	Color 12
				104	111	40.8%	43.5%	Color 13
				112	127	43.9%	49.8%	Color 14
				128	187	50.2%	73.3%	Color continous rotation CW from fast to slow
188	195	73.7%	76.5%	Stop				
196	255	76.9%	100.0%	Color continous rotation CCW from slow to fast				
4	4	5	Gobo wheel (static)	0	10	0.0%	3.9%	Open
				11	21	4.3%	8.2%	Gobo 1
				22	32	8.6%	12.5%	Gobo 2
				33	43	12.9%	16.9%	Gobo 3
				44	54	17.3%	21.2%	Gobo 4
				55	65	21.6%	25.5%	Gobo 5

DMX mode			Name	DMX value		DMX percentage		Function
Standard	Basic	Extended						
4	4	5	Gobo wheel (static)	66	76	25.9%	29.8%	Gobo 6
				77	82	30.2%	32.2%	Gobo 1 shake
				83	88	32.5%	34.5%	Gobo 2 shake
				89	94	34.9%	36.9%	Gobo 3 shake
				95	100	37.3%	39.2%	Gobo 4 shake
				101	106	36.9%	41.6%	Gobo 5 shake
				107	112	42.0%	43.9%	Gobo 6 shake
				113	118	44.3%	46.3%	Gobo7 shake
				119	127	46.7%	49.8%	Gobo 8 shake
				128	187	50.2%	73.3%	Gobo wheel continuous rotation CW from fast to slow
				188	195	73.7%	76.5%	Stop
				196	255	76.9%	100.0%	Gobo wheel continuous rotation CCW from slow to fast
5	5	6	Rotating gobo wheel	0	4	0.0%	1.6%	Open gobo
				5	9	2.0%	3.5%	Gobo 1
				10	14	3.9%	5.5%	Gobo 2
				15	19	5.9%	7.5%	Gobo 3
				20	24	7.8%	9.4%	Gobo 4
				25	29	9.8%	11.4%	Gobo 5
				30	34	11.8%	13.3%	Gobo 6
				35	39	13.7%	15.3%	Gobo 7
				40	47	15.7%	18.4%	Gobo 8
				48	57	18.8%	22.4%	Gobo 1 shake
				58	67	22.7%	26.3%	Gobo 2 shake
				68	77	26.7%	30.2%	Gobo 3 shake
				78	87	30.6%	34.1%	Gobo 4 shake
				88	97	34.5%	38.0%	Gobo 5 shake
				98	107	38.4%	42.0%	Gobo 6 shake
				108	117	42.4%	45.9%	Gobo 7 shake
				118	127	46.3%	49.8%	Gobo 8 shake
				128	187	50.2%	73.3%	Gobo wheel continuous rotation CW from fast to slow
188	195	73.7%	76.5%	Stop				
196	255	76.9%	100.0%	Gobo wheel continuous rotation CCW from slow to fast				
6	6	7	Gobo rotating/positioning gobo wheel	0	127	0.0%	49.8%	Gobo rotation positioning
				128	187	50.2%	73.3%	Gobo continuous rotation CW from slow to fast

DMX mode			Name	DMX value		DMX percentage		Function
Standard	Basic	Extended						
6	6	7	Gobo rotating/positioning gobo wheel	188	195	73.7%	76.5%	Stop
				196	255	76.9%	100.0%	Gobo continuous rotation CCW from slow to fast
		8	Gobo rotation/positioning, fine (LSB)	0	255	0.0%	100.0%	Gobo rotation/positioning, fine (LSB)
7	7	9	Focus	0	255	0.0%	100.0%	Near → Far
		10	Focus, fine (LSB)	0	255	0.0%	100.0%	Focus, fine (LSB)
8	8	11	Prism1	0	31	0.0%	12.2%	Off
				32	127	12.5%	49.8%	Prism (1) On
				128	191	50.2%	74.9%	Prism (2) On
				192	255	75.3%	100.0%	Reserved
9	9	12	Prism1 rotation	0	127	0.0%	49.8%	Prism indexed
				128	187	50.2%	73.3%	Prism continuous rotation CW from fast to slow
				188	195	73.7%	76.5%	Stop
				196	255	76.9%	100.0%	Prism continuous rotation CCW from slow to fast
10	10	13	Prism2	0	31	0.0%	12.2%	Off
				32	127	12.5%	49.8%	Prism (1) On
				128	191	50.2%	74.9%	Prism (2) On
				192	255	75.3%	100.0%	Prism (3) On
11	11	14	Prism2 rotation	0	127	0.0%	49.8%	Prism indexed
				128	187	50.2%	73.3%	Prism continuous rotation CW from fast to slow
				188	195	73.7%	76.5%	Stop
				196	255	76.9%	100.0%	Prism continuous rotation CCW from slow to fast
12	12	15	Prism macro	0	15	0.0%	5.9%	off
				16	135	6.3%	52.9%	macro synchro from slow to fast
				136	255	53.3%	100.0%	macro random from slow to fast
13	13	16	Frost	0	127	0.0%	49.8%	Off
				128	255	50.2%	100.0%	On
14	14	17	Pan	0	255	0.0%	100.0%	Pan
15		18	Pan, fine (LSB)	0	255	0.0%	100.0%	Pan, fine (LSB)
16	15	19	Tilt	0	255	0.0%	100.0%	Tilt
17		20	Tilt, fine (LSB)	0	255	0.0%	100.0%	Tilt, fine (LSB)
18	16	21	Scan speed	0	255	0.0%	100.0%	Scan speed from fast to slow

DMX mode			Name	DMX value		DMX percentage		Function
Standard	Basic	Extended						
19	17	22	Special controls	0	9	0.0%	3.5%	No function
				10	19	3.9%	7.5%	Open light after 5 seconds
				20	29	7.8%	11.4%	Close light after 5 seconds
				30	39	11.8%	15.3%	Color wheel half color switch
				40	49	15.7%	19.2%	Color wheel arbitrary position
				50	59	19.6%	23.1%	Reserved
				60	69	23.5%	27.1%	Reset all motor after 5 seconds
				70	79	27.5%	31.0%	Scan motor reset after 5 seconds
				80	89	31.4%	34.9%	All color motor reset after 5 seconds
				90	99	35.3%	38.8%	All gobo motor reset after 5 seconds
				100	109	39.2%	42.7%	All strobe motor reset after 5 seconds
				110	119	43.1%	46.7%	Other motor reset after 5 seconds
				120	129	47.1%	50.6%	Built-in program 1
				130	139	51.0%	54.5%	Built-in program 2
				140	149	54.9%	58.4%	Built-in program 3
				150	159	58.8%	62.4%	Built-in program 4
				160	169	62.7%	66.3%	Built-in program 5
				170	179	66.7%	70.2%	Built-in program 6
				180	189	70.6%	74.1%	Built-in program 7
				190	199	74.5%	78.0%	Built-in program 8
200	209	78.4%	82.0%	Built-in program 9				
210	219	82.4%	85.9%	Built-in program 10				
220	255	86.3%	100.0%	Reserved				



## 12. Maintenance and Troubleshooting

### 12.1 Cleaning and maintenance

It is required that the fixture should be kept clean and well maintained to ensure its reliability. Its lifespan mainly depends on the working environment and proper operation. Should you have any questions, please consult a technical engineer of GTD Lighting.

 Notes: Damage resulted from dust, smoke, oil or improper use is not covered by warranty.

 Notes: Disconnect the fixture from AC power, and let it cool down for at least 15 minutes before opening the housing. Make sure to use a soft cloth to clean the optical components, and be careful, as the coating is easily scratched. Do not use any organic solvent such as alcohol to clean the reflector mirror, dichroic color filters or housing of the fixture.

- If the lens is cracked or otherwise damaged, replace it immediately.
- If the lamp becomes damaged or deformed in any way it must be replaced.
- If the light from the lamp appears dim, this normally indicates that it is reaching the end of its life span and should be changed at once. Aged lamps run to the extremity of their life might explode.
- If fixture does not function, check the fuse on the power socket of the fixture. Replace the fuse of the same specification if it is blown.
- The fixture is equipped with thermal-protection device that will switch off the lamp in case of overheating. If this happens, please check that the fans are not blocked, and clean them if they are dirty. Check whether the fans are operational. If not, call a qualified technician.

### 12.2 Troubleshooting

Problem	Possible Cause	Suggested Correction
No response after connected to A/C power	Power switch not turned on.	Turn on power switch.
	Take out the fuse and check if it is blown.	Locate the blown fuse. Remove the broken fuse. Insert areplacement fuse of the correct amperage
	Abnormal A/C input (A/C power socket, power cables, luminaire power socket).	Replace AC power socket and power cables, and then adjust power socket for proper connection.
	No DC voltage from switching power supply.	Check if the switching power supply has DC voltage output. Replace the switching power supply.
No response or wrong response to the commands of the control system	DMX cables disconnected from fixture’s DATA IN connector.	Connect DMX cable to the fixture’s DATA IN connector.
	Open circuit or short circuit fault in the DMX cables.	Replace DMX cables as required.
	Wrong DMX address for the fixture in the control system.	Ensure the address in “Run setting > Address Setting >Address” of the fixture is consistent



<b>Problem</b>	<b>Possible Cause</b>	<b>Suggested Correction</b>
		with the address in the control system.
	Misuse in “Channel setting > Channel Mode” of the fixture.	Choose the channel mode in “Channel setting > Channel Mode” of the fixture as required by the user
	Malfunctioning of DMX cannon input/output connectors. No input/output voltage to the main control board of the fixture.	Troubleshooting the DMX XLR signal plate of the fixture, replace the main control board of the fixture.
The lamp does not start when switch is turned on	Normal end of lamp life.	Test the lamp in an adjacent fixture which is known to be operating properly and then replace as necessary
	Whether the function of the relay board is intact, whether the signal is normal or not.	Repair or replace.
	Shorted leads between ballast and the lamp	Replace components as required.
	Incorrect ballast output.	Check ballast output to determine if it conforms to lamp requirements. If voltage and current do not stabilize in five to ten minutes warm-up time, ballast output is incorrect and adjustment should be made. Check capacitor wiring, if visibly available, to determine if capacitors are properly wired.
	Incorrect triggers output.	Replace triggers.
The lamp is off unexpected	The fixture is in sleep mode	Should the fixture is not in active use for “standby time”, the sleep mode is enabled automatically to make it more stable and safer, sleep time can be customized.
	Lamp has been operating: cool down time insufficient.	Environmental conditions such as extreme temperatures will have the fixture stop working, the lamps will require a period of time to cool and re-establish optimum starting conditions. Restart time varies with the degree of ventilation built into it, ambient temperature, and draft conditions.
	Overheat ballast resulting in premature failure or damaged ballast.	The ballast incorporate internal automatic-resetting thermal protection, which deactivates the ballast should it overheat. Normal operation resumes once the ballast has cooled sufficiently.

<b>Problem</b>	<b>Possible Cause</b>	<b>Suggested Correction</b>
		Burned-out or failing lamps, or high temperatures in or around the fixture, can cause the ballast to overheat, so we need solve the problem and replace components as required
	Thermostat damaged.	Replace.
Shaking, wrong position, and out of control gobo wheel	No function the connector between gobo wheel motor and drive, loose, damaged, or broken cables connecting the gobo wheel and drive.	Reconnect the gobo wheel motor to the drive, and replace cables as required.
	The gobo wheel motor's drive IC on the PCB might be out of condition.	Replace the drive having the same software version as required.
	Dislocated magnetic tube and positioning magnet, or damaged magnetic tube.	Calibrate the position of the magnetic tube to the positioning magnet, and replace magnetic tube as required
	Shaking motor, wrong rotation angle, losing step or damaged motor	Replace the motor as required.
Decreased brightness, uneven pattern projections	Normal end of lamp life.	Test the lamp in an adjacent fixture which is known to be operating properly and then replace as necessary
	The midline of the lamp is not aligned with the center point of the effect assembly (consisting of the rotating gobo wheel, static gobo wheel, color wheel, strobe, prism, and frost), focus module, and object lens.	Reinstall the lamp. Adjust the lamp position until the midline of the lamp is aligned with the center point of the effect assemblies (consisting of the rotating gobo wheel,static gobo wheel, color wheel, strobe, prism, frost, the focus adjusting module, and the object lens).
	Excessive dusts or smudges on the effect assembly, focus module and objective lens.	Follow the instructions stated in this user manual to clean the effect assembly, focus module and objective lens.
	Damaged or deformed effect assembly, focus module or objective lens.	Replace the damaged or deformed components
Wrong color	Normal end of lamp life	Test the lamp in an adjacent fixture which is known to be operating properly and then replace as necessary
	Excessive dusts or smudges on the rotating gobo wheel or color wheel.	Follow the instructions stated in this user manual to clean the rotating gobo wheel or color wheel.

<b>Problem</b>	<b>Possible Cause</b>	<b>Suggested Correction</b>
	Rotating gobo wheel, color wheel with coating wearing off, damages or deformation	Replace the worn-off, damaged or deformed rotating gobo wheel and color wheel
Non-clear shape	Excessive dusts or smudges on the rotating gobo wheel or color wheel	Follow the instructions stated in this user manual to clean the rotating gobo wheel or color wheel.
	Excessive dusts or smudges on the focus module or objective lens	Follow the instructions stated in this user manual to clean the focus module or objective lens
	Damaged or deformed focus module or objective lens.	Replace the damaged or deformed focus module or objective lens.

### 13. Spare parts list

Name	P/N	Qty	Notes
Lamp	1306030013A	1	OSRAM SIRIUS HRI 461W
Switch power	1412050083A	1	EDS850-38528P 385V 1.5A/28V 10A
Electronic trigger	5801913003A	1	PT SIRIUS 461W - UNISHAPE
Display	5809010471A	1	F4 II BEAM-101A10 SDI8003C
Scan board	5809010472A	1	F4 II BEAM-201A10 SCR8004D
Fan drive board	5809010475A	1	F4 II BEAM-501A10 SJC8003A
Motor drive board3	5809010474A	1	F4 II BEAM-401A10 SCR8011A
Motor drive board4	5809010473A	1	F4 II BEAM-301A10 SCR8010A



Guangzhou GTD Culture & Technology Group Co., Ltd.

Tel : 86-20-61808288

Fax : 86-20-61812282

<http://www.gtd-china.com>