

ACME[®]

LYRA

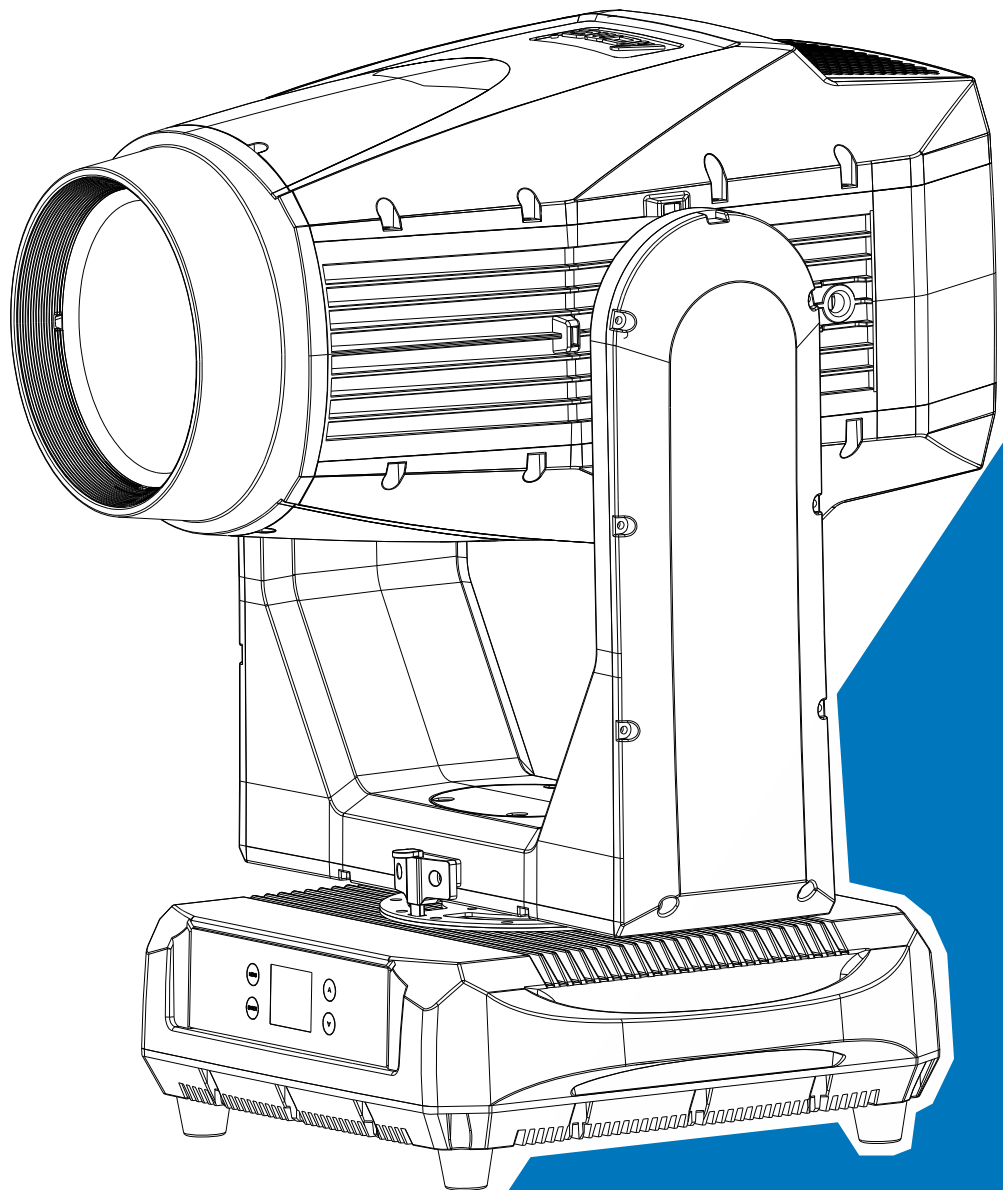

Intertek
5000057

User Manual

Please read the instruction carefully before use

CONTENTS

01/ Safety Instructions.....	2
02/ Technical Specifications	6
03/ Control Panel.....	8
04/ Fixture Installation.....	9
05/ Effect Wheels.....	11
06/ How To Set The Unit.....	12
6.1 Main Functions.....	12
6.2 Home Position Adjustment	26
07/ Control By Universal DMX Controller.....	36
7.1 DMX512 Connection.....	36
7.2 Address Setting.....	37
7.3 DMX512 Configuration.....	37
08/ Error Information	57
09/ Troubleshooting	67
10/ Fixture Cleaning.....	68

01/ Safety Instructions



Please read the instruction carefully which includes important information about the installation, usage and maintenance.

WARNING

Please keep this User Guide for future consultation. If you sell the unit to another user, be sure that they also receive this instruction manual.

Important:

Damages caused by the disregard of this user manual are not subject to warranty. The dealer will not accept liability for any resulting defects or problems.

- Unpack and check carefully to ensure that there is no transportation damage before using the unit.
- This product is suitable for wet locations. Do not immerse in water.
- DO install and operate by qualified operator.
- DO NOT allow children to operate the fixture.
- Use safety chain when fixing the unit. Handle the unit by carrying its base instead of head only.
- The unit must be installed in a location with adequate ventilation, at least 50cm from adjacent surfaces.
- Be sure that no ventilation slots is blocked, otherwise the unit will be overheated.
- Before operation, ensure that you are connecting this product to the proper voltage in accordance with the specifications in this manual or on the product's specification label.
- It's important to ground the yellow/green conductor to earth in order to avoid electric shock.
- Minimum ambient temperature TA: 0°C. Maximum ambient temperature TA: 40°C. Do not operate this product at a lower or higher temperature.
- DO NOT connect the device to any dimmer pack.
- Keep flammable materials away from the fixture while operating to avoid fire hazard.
- Make sure the power cord is not crimped or damaged; replace it immediately if damaged.
- Unit's surface temperature may reach up to 75°C. DO NOT touch the housing bare-handed during its operation.
- Avoid any flammable liquids, water or metal from entering the unit. Once it happens, cut

off the mains power immediately.

- DO NOT operate in a dirty or dusty environment. DO clean the fixture regularly.
- DO NOT touch any wire during operation as there might be a hazard of electric shock.
- Avoid entanglement of the power cord with other wires.
- The minimum distance to objects/surface must be more than 3 meters.
- In the event of serious operating problem, stop using the unit immediately.
- Never turn on and off the unit time after time.
- The housing, the lenses, or the ultraviolet filter must be replaced if they are visibly damaged.
- DO NOT open the housing as there are no user serviceable parts inside.
- DO NOT attempt to operate this unit if it becomes damaged. DO NOT attempt any repairs yourself. Repairs carried out by unskilled people can lead to damage or malfunction. Please contact the nearest authorized technical assistance center if needed.
- Disconnect this product from its power source before servicing.
- DO use the original packaging if the device is to be transported.
- Avoid direct eye exposure to the light source while the product is on.
- DO NOT operate this product if you see damage on the housing, shields, or cables. Have the damaged parts replaced by an authorized technician at once.

01/ Consignes de sécurité



Veillez lire attentivement les instructions qui contiennent des informations importantes sur l'installation, l'utilisation et l'entretien.

ATTENTION

Veillez conserver ce guide de l'utilisateur pour une consultation future. Si vous vendez l'appareil à un autre utilisateur, assurez-vous qu'il reçoive également ce manuel d'instructions.

Important:

Les dommages causés par le non-respect de ce manuel d'utilisation ne sont pas couverts par la garantie. Le revendeur n'acceptera aucune responsabilité pour les défauts ou problèmes qui en résultent.

- Déballez et vérifiez soigneusement qu'il n'y a pas de dommages dus au transport avant d'utiliser l'appareil.
- Ce produit convient aux endroits humides. Ne pas immerger dans l'eau.
- L'installation et la mise en fonctionnement doit être effectué par un opérateur qualifié.
- NE PAS permettre aux enfants d'utiliser l'appareil.
- Utilisez une chaîne de sécurité lors de la fixation de l'unité. Manipulez l'appareil en portant sa base au lieu de la tête uniquement.
- L'unité doit être installée dans un endroit avec une ventilation adéquate, à au moins 50cm des surfaces adjacentes.
- Assurez-vous qu'aucune fente d'aération du luminaire n'est obstruée, sinon il risque de surchauffer.
- Avant toute utilisation, assurez-vous que vous connectez ce luminaire à la tension appropriée conformément aux spécifications que vous trouverez dans ce manuel ou sur l'étiquette des spécifications collée sur la base du luminaire.
- Il est important de relier le file jaune/vert à la terre afin d'éviter tout choc électrique.
- Température ambiante minimale TA: 0°C. Température ambiante maximale TA: 40°C. N'utilisez pas ce luminaire à des températures inférieures ou supérieures.
- NE PAS connecter le luminaire à un pack de gradateurs.
- Gardez les matériaux inflammables à l'écart du luminaire pendant le fonctionnement pour éviter tout risque d'incendie.

- Assurez-vous que le cordon d'alimentation n'est pas pincé ou endommagé; remplacez-le immédiatement s'il est endommagé.
- La température de surface de l'unité peut atteindre 75°C. NE PAS toucher les capots à mains nues pendant son fonctionnement.
- Évitez que des liquides inflammables, de l'eau ou du métal ne pénètrent dans l'appareil. Si cela se produit, coupez immédiatement l'alimentation secteur.
- NE PAS utiliser le luminaire dans un environnement sale ou poussiéreux. Cette appareil doit être nettoyer régulièrement.
- NE touchez AUCUN file pendant le fonctionnement car il pourrait y avoir un risque de choc électrique.
- Évitez l'enchevêtrement du cordon d'alimentation avec d'autres fils.
- La distance minimale de projection sur des objets ou sur des surfaces doit être supérieure à 3 mètres.
- En cas de problème de fonctionnement grave, arrêtez immédiatement d'utiliser l'appareil.
- N'allumez et n'éteignez jamais ce luminaire à maintes reprises.
- Le boîtier, les lentilles ou le filtre ultraviolet doivent être remplacés s'ils sont visiblement endommagés.
- NE PAS ouvrir le boîtier car il ne contient aucune pièce réparable par l'utilisateur.
- NE PAS mettre ce luminaire en fonctionnement s'il est endommagé. N'effectuez pas de réparations vous-même. Les réparations ne doivent être effectuées par des personnes non qualifiées, cela peut entraîner des dommages ou des dysfonctionnements. Veuillez contacter le centre d'assistance technique agréé le plus proche si nécessaire.
- Débranchez ce produit du secteur avant de procéder à l'entretien.
- Utiliser l'emballage d'origine si l'appareil doit être transporté.
- Évitez une exposition directe des yeux à la source lumineuse lorsque le produit est allumé.
- N'utilisez PAS ce produit si vous constatez des dommages sur le boîtier, les blindages ou les câbles. Faites remplacer immédiatement les pièces endommagées par un technicien agréé.

02/ Technical Specifications

Power Voltage	100-240V~ 50/60Hz	
Power Consumption	1200W	
Light Source	SCL1000Y-80-R72	
Color Temperature	6500K	
Zoom Range	6°-50°	
Dimmer/Strobe	0-100% smooth dimming; Outstanding strobe effect with variable speed	
Color Wheel	5 colors plus frost and cri and rainbow effect	
Gobo Wheel	Static Gobo Wheel	9 gobos plus open
	Rotating Gobo Wheel	7 gobos plus open, convenient replacement
Movement	Pan	540°
	Tilt	260°
	Pan/Tilt Resolution	16 bit
	Automatic pan/tilt position correction	
	Fixation	Pan/Tilt lock
Control	DMX Channel	39/30/31/22/40 Channels
	Control Mode	DMX512
		RDM
Firmware Upgrade	Firmware Upgrade via DMX link	
Construction	Display	LCD display
	Data In/Out	3-pin IP XLR (5-pin IP XLR is optional)
	Power In/Out	Waterproof Power Connector in/out
	Protection Rating	IP66

Description for power cord set should be used: Listed SJOW flexible cord with rating: 300V, 105°C, VW-1, 16AWGx3C, molded with 5-15P attachment plug and terminated with cord connector model SAC3FX with rating 250V, 16A, T80 by NINGBO HAISHU DISTRICT SEETRONIC ELECTRONIC CO., LTD. The length of power cord shall be at least 914mm and not greater than 2m (6.6 feet) in length (It is to be measured from the face of the attachment plug to the face of the Cord Connector which is connected on the Power Cord Set). And it shall make the resistance of the grounding circuit less than 0.1ohm.

Features	Standard Mode: Ra>70	
	High CRI Mode: Ra>90	
	High CRI filter used to switch to HCRI mode	
	Linear CMY color mixing	
	Variable CTO	
	1 x animation wheel with outstanding water and flame effect	
	Motorized linear iris	
	1 x 4-facet prism rotatable in either direction 1 x 4-facet linear prism rotatable in either direction	
	2 different frost filters to create and improve the wash effect. They can be used independently and overlaid	
	4 x fast and smooth framing shutters; The position and the angle of each shutter blade can be controlled individually; Each shutter blade can block out light completely; The framing module can be rotated at ± 60 degrees	
IP66 protection rotating, can be used outdoors all year round		
Dimensions	412x330x718mm	16.2"x13"x28.3" in
Weight	42kgs	92.6lbs

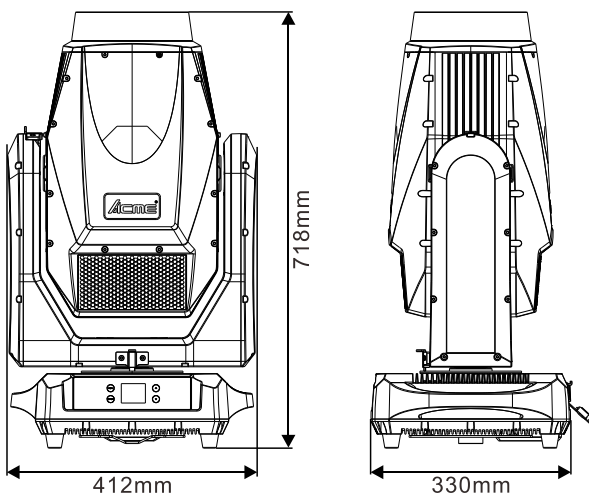

Photometric Diagram:

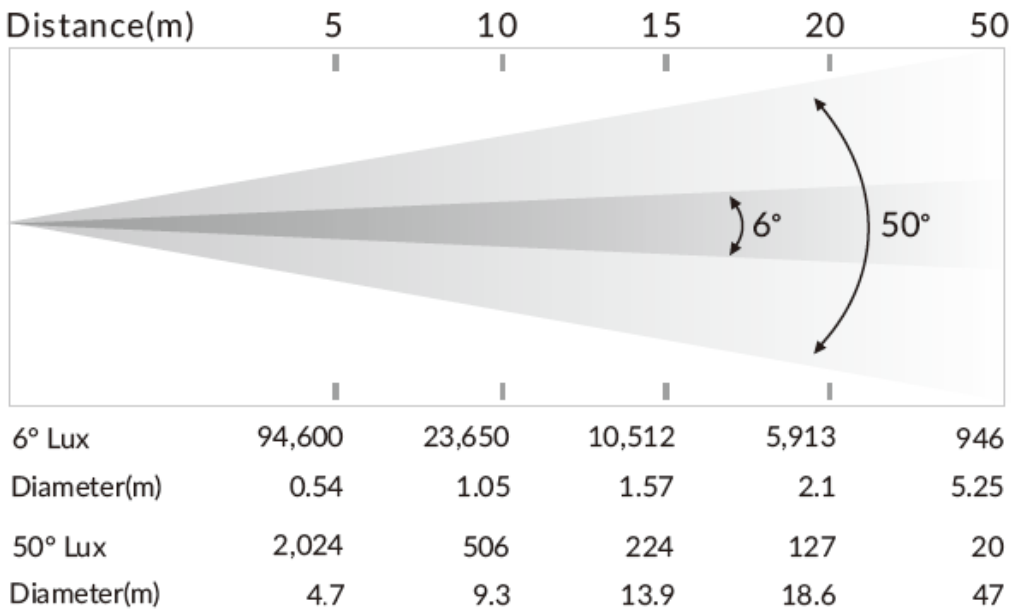

03/ Control Panel

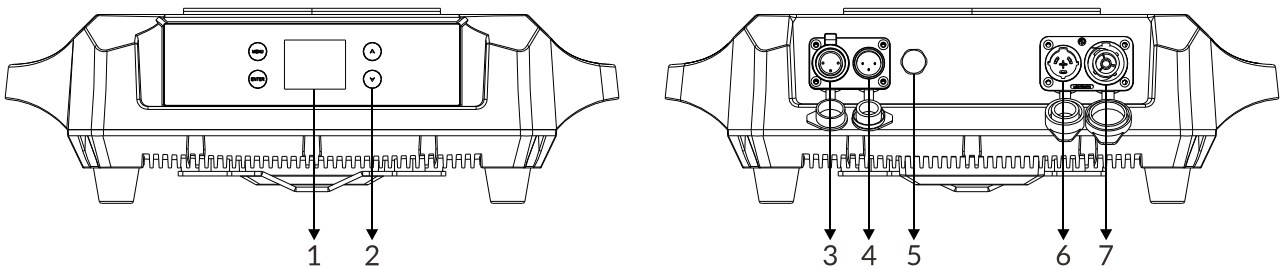

1. Display	To show the various menus and the selected function	
2. Buttons	MENU	To enter into move backward or leave the menu
	▲ UP	To go backward to move up in the menu
	▼ DOWN	To go forward to move down in the menu
	ENTER	To perform the desired functions
3. DMX OUT	For DMX512 link, use 3-pin XLR cable to link the next units to output DMX signal (5-pin XLR cable is optional)	
4. DMX IN	For DMX512 link, use 3-pin XLR cable to link the unit and DMX controller to input DMX signal (5-pin XLR cable is optional)	
5. RELEASE VALVE		
6. POWER IN	To connect to supply power	
7. POWER OUT	To connect to the next fixture	

04/ Fixture Installation

- ▶ DO install and operate by qualified operator. Fixture(s) should be installed in areas outside walking paths, seating areas, or away from areas where unauthorized personnel might reach the fixture by hand. NEVER stand directly below the fixture(s) when rigging, removing or servicing.
- ▶ Always ensure that the unit is firmly fixed to avoid vibration and slipping off during operation. Ensure that the trussing or area of installation must be able to hold 10 times the weight without any deformation. Always attach a safety cable that can hold at least 12 times the weight of the fixture whenever installing this fixture in a suspended environment to ensure that the fixture will not fall if the clamp fails.
- ▶ This fixture is fully operational in three different mounting positions: hanging upside-down, mounted sideways on trussing, or standing on the floor. Always use and install the supplied safety cable as a safety measure to prevent accidental damage and/or injury in the event the clamp fails.

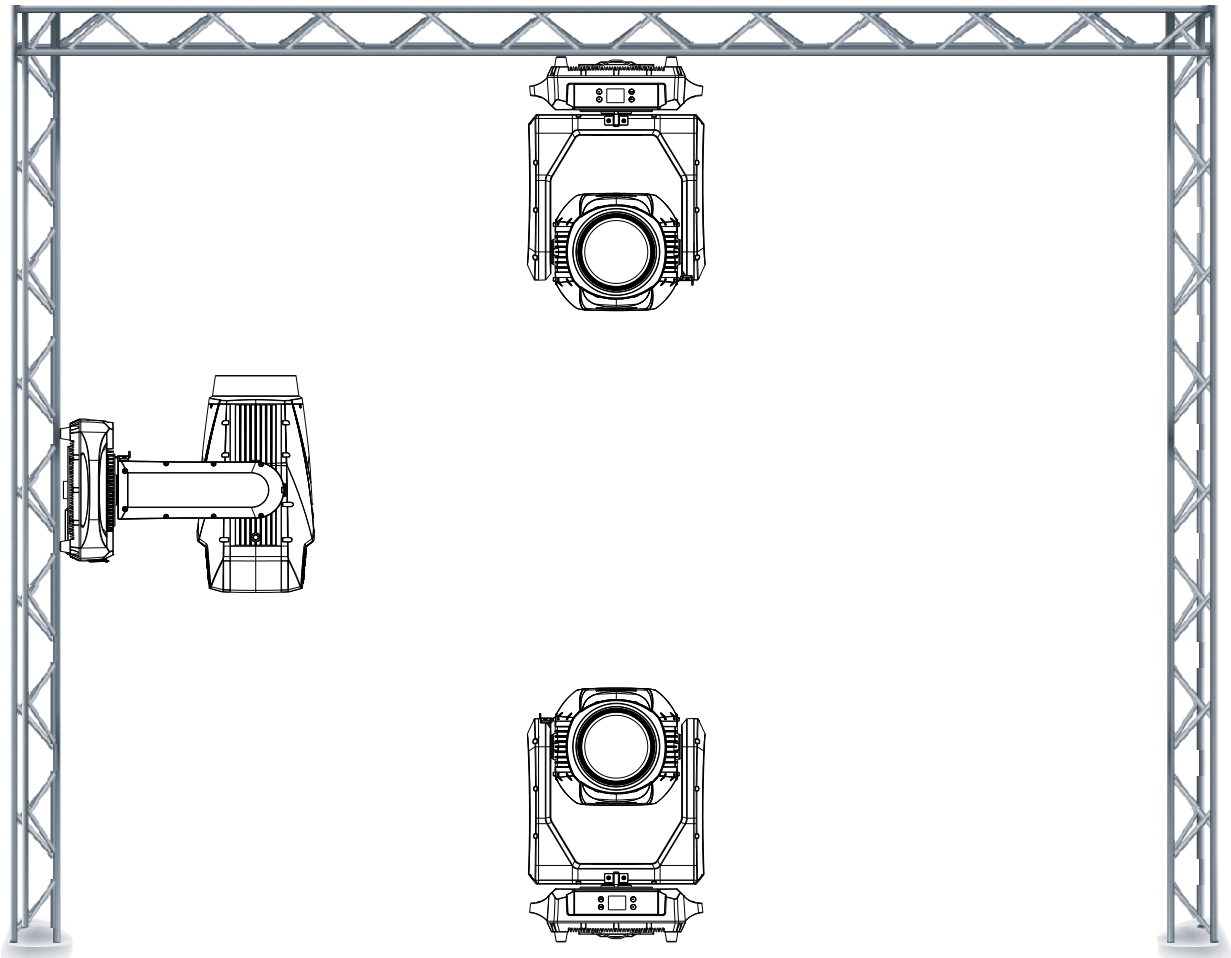

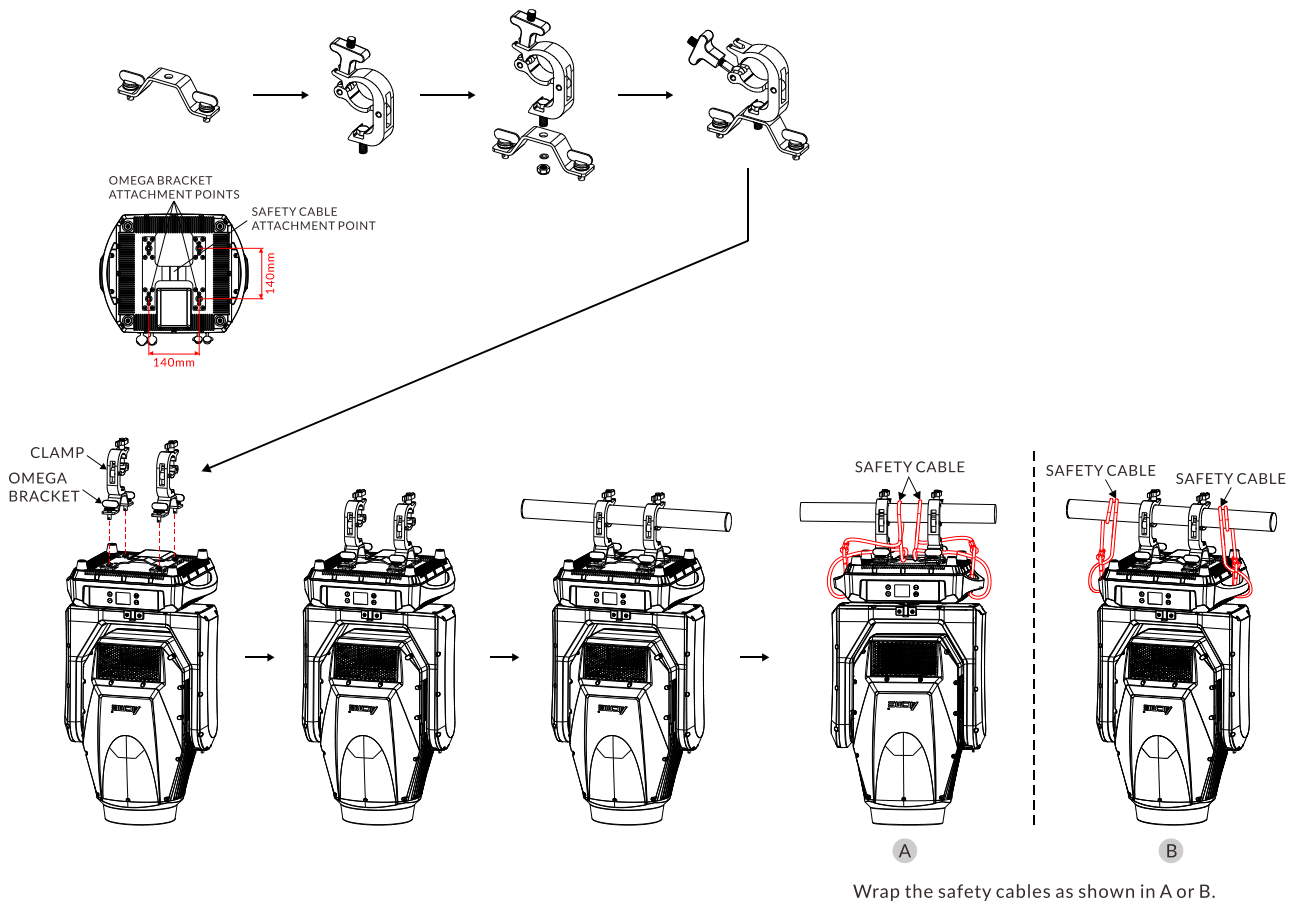

Caution: For security reasons, you need to loop and wrap safety cables through fixture base handle and route and wrap through center bracket on fixture base (A). Or pull the safety cables through the handle and around the truss (B).

The safety cable must be secured to keep from interfering with the pan and tilt movement of the fixture.

05/ Effect Wheels

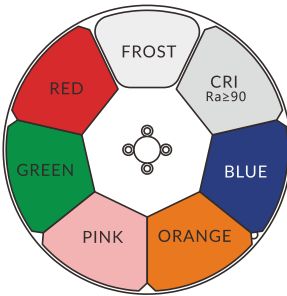

COLOR WHEEL

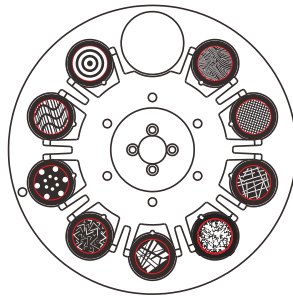

STATIC GOBO WHEEL

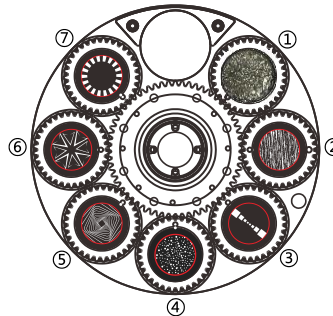

ROTATING GOBO WHEEL

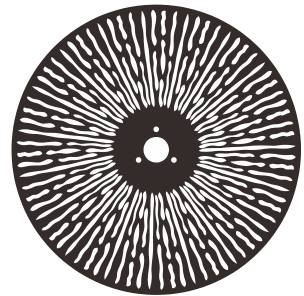

ANIMATION WHEEL

DANGER!

Install the rotating gobos with the device switched off only.

Unplug from mains before changing the rotating gobos!

R-Gobos	Part Number
① Gobo1	3015000886
② Gobo2	3011001338
③ Gobo3	3011001337
④ Gobo4	3011001099
⑤ Gobo5	3011001327
⑥ Gobo6	3011001336
⑦ Gobo7	3011001329

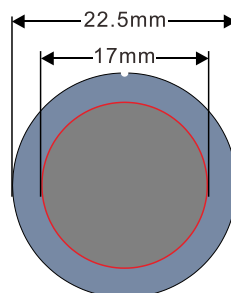

Rotating Gobos
Dimensions

06/ How To Set The Unit

6.1 Main Functions

- ▶ To access the control menus, press the [MENU] button.
- ▶ Navigate the menu structure, using the [ENTER], [▲ UP] and [▼ DOWN] buttons.
- ▶ To select a menu option or to confirm a selection, press the [ENTER] button.
- ▶ To return to a higher level in the menu structure without making a change, press the [MENU] button, or wait 30 seconds.

The screen will be automatically locked if there is no operation for a long time, and can be unlocked by long-pressing the [MENU] button.

The main functions are shown below:

MENU	SUBMENU	OPTIONS		
DMX Settings	DMX Address	1-474 (39 CH)	(Default=1)	
		1-483 (30 CH)		
		1-482 (31 CH)		
		1-491 (22 CH)		
		1-473 (40 CH)		
	DMX Channel Mode	(39) Framing		
		(30) Spot		
		(31) F-Wash		
		(22) Wash		
		(40)		
	No DMX Status	Blackout		
		Hold		
		Manual		
	View DMX Value			
Fixture Settings	Pan Invert	No		
		Yes		
	Tilt Invert	No		
		Yes		
	P/T Feedback	No		
		Yes		
	Dimmer Speed	Fast		
		Smooth		

MENU	SUBMENU	OPTIONS	
	Dimmer Curve	Square Law	
		Inv SQ Law	
		Linear	
		S Curve	
	Led Refresh Rate	900Hz	
		1000Hz	
		1100Hz	
		1200Hz	
		1300Hz	
		1400Hz	
		1500Hz	
		2500Hz	
		4000Hz	
		5000Hz	
		6000Hz	
		10KHz	
		15KHz	
		20KHz	
	25KHz		
	Cooling Mode	Standard	
		Quiet	
		Theatre	
	Bright Calibration	50-100	(Default=100)
Blade Mode	Mode 1		
	Mode 2		
Gobo Short Cut	Enable		
	Disable		
Color Short Cut	Enable		
	Disable		
Display Settings	Display Invert	No	
		Yes	
	Backlight Intensity	1-10	(Default=10)
	Temperature Unit	°C	
		°F	
	Language	English	
Chinese			

MENU	SUBMENU	OPTIONS	
Fixture Test	Auto Test	Clear	No/Yes
	Manual Test	Pan	0-255
		Tilt	0-255
		Cyan	0-255
		Magenta	0-255
		Yellow	0-255
		Cto	0-255
		Color	0-255
		Gobo	0-255
		R-Gobo	0-255
		Gobo 2	0-255
		Animation	0-255
		Iris	0-255
		Prism 1	0-255
		R-Prism 1	0-255
		Prism 2	0-255
		R-Prism 2	0-255
		CRI	0-255
		Frost 1	0-255
		Frost 2	0-255
		Zoom	0-255
		Focus	0-255
		Strobe	0-255
		Dimmer	0-255
		Blade	0-255
		Blade Down 1	0-255
		Blade Down 2	0-255
		Blade Up 1	0-255
		Blade Up 2	0-255
	Blade Left 1	0-255	
Blade Left 2	0-255		
Blade Right 1	0-255		
Blade Right 2	0-255		

MENU	SUBMENU	OPTIONS		
Fixture Information	Fixture Use Hour			
	LED Use Hour	Total LED Hour		
		LED On Hour		
		LED Hours Reset	Password=050	
	Humidity		Current	Max
		Base		
		Head		
	Temperature		Current	Max temp
		LED's		
	Fan State	B_FAN 1~3		
		A_FAN 1		
		H_FAN 1~12		
	Firmware Version			
	RDM UID			
	Error Logs	Fixture Errors		
Reset Error Log		No		
		Yes	Password=050	
Reset Function	Pan/Tilt Reset	No		
		Yes		
	Effect Reset	No		
		Yes		
	All Reset	No		
		Yes		
Special Function	Factory Settings	No		
		Yes		

DMX Settings

Enter the control menu and select **DMX Settings**, press ENTER. Use the UP/DOWN button to select **DMX Address**, **DMX Channel Mode**, **No DMX Status** or **View DMX Value**.

DMX Address

Select **DMX Address**, press ENTER.

Use UP/DOWN button to select an address, confirm your selection with ENTER.

CHANNEL MODE	DMX ADDRESS
(39) Framing	1-474
(30) Spot	1-483
(31) F-Wash	1-482
(22) Wash	1-491
(40)	1-473

To exit the menu, press MENU, or wait 30 seconds.

DMX Channel Mode

Select **DMX Channel Mode**, press ENTER.

Use UP/DOWN button to select between **(39) Framing**, **(30) Spot**, **(31) F-Wash**, **(22) Wash** and **(40)**, confirm your selection with ENTER.

To exit the menu, press MENU, or wait 30 seconds.

No DMX Status

Select **No DMX Status**, press ENTER.

Use UP/DOWN button to select one of the following status:

Blackout (Fixture blacks out if DMX signal stops)

Hold (The device continues to operate in the current mode with the last active DMX values until the signal returns)

Manual (The device accepts the DMX value stored in the 'Manual Test' menu)

Confirm your selection with ENTER.

To exit the menu, press MENU, or wait 30 seconds.

View DMX Value

Select **View DMX Value**, press ENTER.

Use UP/DOWN button to select the desired DMX channel, for which the value is to be displayed.

To exit the menu, press MENU, or wait 30 seconds.

Fixture Settings

Enter the control menu and select **Fixture Settings**, press ENTER. Use the UP/DOWN button to select **Pan Invert**, **Tilt Invert**, **P/T Feedback**, **Dimmer Speed**, **Dimmer Curve**, **Led Refresh Rate**, **Cooling Mode**, **Bright Calibration**, **Blade Mode**, **Gobo Short Cut** or **Color Short Cut**.

Pan Invert

Select **Pan Invert**, press ENTER.

Use UP/DOWN button to select **No** (pan invert deactivated) or **Yes** (pan invert activated), confirm your selection with ENTER.

To exit the menu, press MENU, or wait 30 seconds.

Tilt Invert

Select **Tilt Invert**, press ENTER.

Use UP/DOWN button to select **No** (tilt invert deactivated) or **Yes** (tilt invert activated), confirm your selection with ENTER.

To exit the menu, press MENU, or wait 30 seconds.

P/T Feedback

Select **P/T Feedback**, press ENTER.

Use UP/DOWN button to select **No** (pan/tilt feedback deactivated) or **Yes** (pan/tilt feedback activated), confirm your selection with ENTER.

To exit the menu, press MENU, or wait 30 seconds.

Dimmer Speed

Select **Dimmer Speed**, press ENTER.

Use UP/DOWN button to select **Fast** or **Smooth**, confirm your selection with ENTER.

To exit the menu, press MENU, or wait 30 seconds.

Dimmer Curve

Select **Dimmer Curve**, press ENTER.

Use UP/DOWN button to select **Square Law**, **Inv SQ Law**, **Linear** or **S Curve**, confirm your selection with ENTER.

Dimmer Modes

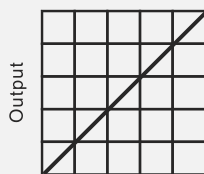

Optically Linear

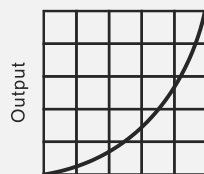

Square Law

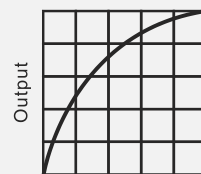

Inverse Square Law

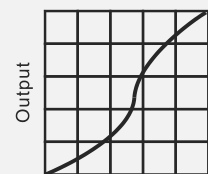

S-curve

To exit the menu, press MENU, or wait 30 seconds.

Led Refresh Rate

Select **Led Refresh Rate**, press ENTER.

Use UP/DOWN button to select **900Hz**, **1000Hz**, **1100Hz**, **1200Hz**, **1300Hz**, **1400Hz**, **1500Hz**, **2500Hz**, **4000Hz**, **5000Hz**, **6000Hz**, **10KHz**, **15KHz**, **20KHz** or **25KHz**, confirm your selection with ENTER.

To exit the menu, press MENU, or wait 30 seconds.

Cooling Mode

Select **Cooling Mode**, press ENTER.

Use UP/DOWN button to select **Standard**, **Quiet** or **Theatre**, confirm your selection with ENTER.

To exit the menu, press MENU, or wait 30 seconds.

Bright Calibration

Select **Bright Calibration**, press ENTER.

Use UP/DOWN button to select a value between **50** and **100**, confirm your selection with ENTER.

To exit the menu, press MENU, or wait 30 seconds.

Blade Mode

Select **Blade Mode**, press ENTER.

Use UP/DOWN button to select **Mode 1** or **Mode 2**, confirm your selection with ENTER.

To exit the menu, press MENU, or wait 30 seconds.

Gobo Short Cut

Select **Gobo Short Cut**, press ENTER.

Use UP/DOWN button to select **Enable** or **Disable**, confirm your selection with ENTER.

To exit the menu, press MENU, or wait 30 seconds.

Color Short Cut

Select **Color Short Cut**, press ENTER.

Use UP/DOWN button to select **Enable** or **Disable**, confirm your selection with ENTER.

To exit the menu, press MENU, or wait 30 seconds.

Display Settings

Enter the control menu and select **Display Settings**, press ENTER. Use the UP/DOWN button to select **Display Invert**, **Backlight Intensity**, **Temperature Unit** or **Language**.

Display Invert

Select **Display Invert**, press ENTER.

Use UP/DOWN button to select **No** (display normal) or **Yes** (display inverted), confirm your selection with ENTER.

To exit the menu, press MENU, or wait 30 seconds.

Backlight Intensity

Select **Backlight Intensity**, press ENTER.

Use UP/DOWN button to select a value between **1** (dark) and **10** (bright), confirm your selection with ENTER.

To exit the menu, press MENU, or wait 30 seconds.

Temperature Unit

Select **Temperature Unit**, press ENTER.

Use UP/DOWN button to select **°C** or **°F**, confirm your selection with ENTER.

To exit the menu, press MENU, or wait 30 seconds.

Language

Select **Language**, press ENTER.

Use UP/DOWN button to select **English** or **Chinese**, confirm your selection with ENTER.

To exit the menu, press MENU, or wait 30 seconds.

Fixture Test

Enter the control menu and select **Fixture Test**, press ENTER. Use the UP/DOWN button to select **Auto Test** or **Manual Test**.

Auto Test

Select **Auto Test**, press ENTER.

The device immediately performs an automatic self-test.

To end the automatic self-test and exit the menu, press MENU, or wait 30 seconds.

Manual Test

Select **Manual Test**, press ENTER.

Use UP/DOWN button to select the channel for which the manual test is to be performed, confirm your selection with ENTER.

Use UP/DOWN button to select a value, confirm your selection with ENTER.

To exit the menu, press MENU, or wait 30 seconds.

(The device returns to its original DMX state after the manual test. The test values are saved automatically when the device is switched off.)

Fixture Information

Enter the control menu and select **Fixture Information**, press ENTER. Use the UP/DOWN button to select **Fixture Use Hour**, **LED Use Hour**, **Humidity**, **Temperature**, **Fan State**, **Firmware Version**, **RDM UID** or **Error Logs**.

Fixture Use Hour

Select **Fixture Use Hour**, press ENTER.

The operating hours is displayed.

To exit the menu, press MENU, or wait 30 seconds.

LED Use Hour

Select **LED Use Hour**, press ENTER.

Use UP/DOWN button to select **Total LED Hour** (total time) or **LED On Hour** (current switch-on time), confirm your selection with ENTER.

The total time or current switch-on time is displayed.

Use UP/DOWN button to select **LED Hours Reset**, confirm your selection with ENTER.

Use UP/DOWN button to set the password 050, confirm your selection with ENTER. The LED operating hours is reset.

To exit the menu, press MENU, or wait 30 seconds.

Humidity

Select **Humidity**, press ENTER.

The device humidity is displayed.

To exit the menu, press MENU, or wait 30 seconds.

Temperature

Select **Temperature**, press ENTER.

The device temperature is displayed.

To exit the menu, press MENU, or wait 30 seconds.

Fan State

Select **Fan State**, press ENTER.

The fan status is displayed.

To exit the menu, press MENU, or wait 30 seconds.

Firmware Version

Select **Firmware Version**, press ENTER.

The firmware version is displayed.

To exit the menu, press MENU, or wait 30 seconds.

RDM UID

Select **RDM UID**, press ENTER.

The RDM UID is displayed.

To exit the menu, press MENU, or wait 30 seconds.

Error Logs

Select **Error Logs**, press ENTER.

Use UP/DOWN button to select **Fixture Errors**, confirm your selection with ENTER.

The error list is displayed.

Use UP/DOWN button to select **Reset Error Log**, confirm your selection with ENTER.

If you wish to reset the relevant error logs, select **Yes**. If you do not wish to reset anything, select **No**. Confirm your selection with ENTER.

If you select **Yes**, use UP/DOWN button to set the password 050, confirm your selection with ENTER. The relevant error logs are reset.

To exit the menu, press MENU, or wait 30 seconds.

Reset Function

Enter the control menu and select **Reset Function**, press ENTER. Use the UP/DOWN button to select **Pan/Tilt Reset**, **Effect Reset** or **All Reset**.

Pan/Tilt Reset

Select **Pan/Tilt Reset**, press ENTER.

Use UP/DOWN button to select **No** or **Yes** (the device will run built-in program to reset pan/tilt to their home positions), confirm your selection with ENTER.

To exit the menu, press MENU, or wait 30 seconds.

Effect Reset

Select **Effect Reset**, press ENTER.

Use UP/DOWN button to select **No** or **Yes** (the device will run built-in program to reset effect to their home positions), confirm your selection with ENTER.

To exit the menu, press MENU, or wait 30 seconds.

All Reset

Select **All Reset**, press ENTER.

Use UP/DOWN button to select **No** or **Yes** (the device will run built-in program to reset all to their home positions), confirm your selection with ENTER.

To exit the menu, press MENU, or wait 30 seconds.

Special Function

Enter the control menu and select **Special Function**, press ENTER. Use the UP/DOWN button to select **Factory Settings**.

Factory Settings

Select **Factory Settings**, press ENTER.

If you wish to reset the device to the factory settings, select **Yes**. If you do not wish to reset anything, select **No**. Confirm your selection with ENTER.

To exit the menu, press MENU, or wait 30 seconds.

RDM functions: Certain menus of the device and functions can be called up via the RDM protocol.

The parameter IDs are implemented as follows for different commands:

Parameter ID	Command 'Discovery'	Command 'Set'	Command 'Get'
DISC_UNIQUE_BRANCH	✓		
DISC_MUTE	✓		
DISC_UN_MUTE	✓		
DEVICE_INFO			✓
SUPPORTED_PARAMETERS			✓
SOFTWARE_VERSION_LABEL			✓
DMX_START_ADDRESS		✓	✓
IDENTIFY_DEVICE		✓	✓
DEVICE_MODEL_DESCRIPTION			✓
PARAMETER_DESCRIPTION			✓
MANUFACTURER_LABEL			✓
DEVICE_LABEL		✓	✓
FACTORY_DEFAULTS		✓	✓
BOOT_SOFTWARE_VERSION_ID			✓
BOOT_SOFTWARE_VERSION_LABEL			✓
DMX_PERSONALITY		✓	✓
DMX_PERSONALITY_DESCRIPTION			✓
SLOT_INFO			✓
SLOT_DESCRIPTION			✓
SENSOR_DEFINITION			✓
SENSOR_VALUE			✓
DEVICE_HOURS			✓
LAMP_HOURS			✓
PAN_INVERT		✓	✓
TILT_INVERT		✓	✓
RESET_DEVICE		✓	
CURVE		✓	
DMX_STATE		✓	✓
DIMMER_SPEED		✓	✓

✓ -Command implemented for the respective parameter ID

6.2 Home Position Adjustment

- ▶ To access the control menus, press the [MENU] button.
- ▶ To access the offset menus, long-press the [ENTER] button.
- ▶ Navigate the offset menus, using the [ENTER], [▲ UP] and [▼ DOWN] buttons.
- ▶ To select a menu option or to confirm a selection, press the [ENTER] button.
- ▶ To return to a higher level in the menu structure without making a change, press the [MENU] button, or wait 30 seconds.

OFFSET MENU	VALUES
Frequency(Hz)	1072~1327
Dimming Start	0~999
Dim 1 Offset	-128~127
Dim 2 Offset	-128~127
Dim 3 Offset	-128~127
Dim 4 Offset	-128~127
Dim 5 Offset	-128~127
Dim 6 Offset	-128~127
Dim 7 Offset	-128~127
Pan	-128~127
Tilt	-128~127
Cyan	-128~127
Magenta	-128~127
Yellow	-128~127
Cto	-128~127
Color	-128~127
Gobo	-128~127
R-Gobo	-128~127
Gobo 2	-128~127
Animation	-128~127
Iris	-128~127
Prism 1	-128~127
R-Prism 1	-128~127
Prism 2	-128~127
R-Prism 2	-128~127
Frost 1	-128~127

Frost 2	-128~127
Zoom	-128~127
Focus	-128~127
Blade	-128~127
Blade Down 1	-128~127
Blade Down 2	-128~127
Blade Up 1	-128~127
Blade Up 2	-128~127
Blade Left 1	-128~127
Blade Left 2	-128~127
Blade Right 1	-128~127
Blade Right 2	-128~127

Frequency(Hz)

Select **Frequency(Hz)**, press ENTER.

Use UP/DOWN button to select a value, confirm your selection with ENTER.

To exit the offset menu, press MENU, or wait 30 seconds.

Frequency	VALUES
900Hz	772~1027
1000Hz	872~1127
1100Hz	972~1227
1200Hz	1072~1327
1300Hz	1172~1427
1400Hz	1272~1527
1500Hz	1372~1627
2500Hz	2372~2627
4000Hz	3872~4127
5000Hz	4872~5127
6000Hz	5872~6127
10KHz	9872~10127
15KHz	14872~15127
20KHz	19872~20127
25KHz	24872~25127

Dimming Start

Select **Dimming Start**, press ENTER.

Use UP/DOWN button to select a value between 0 and 999, confirm your selection with ENTER.

To exit the offset menu, press MENU, or wait 30 seconds.

Dim 1 Offset

Select **Dim 1 Offset**, press ENTER.

Use UP/DOWN button to select a value between -128 and 127, confirm your selection with ENTER.

To exit the offset menu, press MENU, or wait 30 seconds.

Dim 2 Offset

Select **Dim 2 Offset**, press ENTER.

Use UP/DOWN button to select a value between -128 and 127, confirm your selection with ENTER.

To exit the offset menu, press MENU, or wait 30 seconds.

Dim 3 Offset

Select **Dim 3 Offset**, press ENTER.

Use UP/DOWN button to select a value between -128 and 127, confirm your selection with ENTER.

To exit the offset menu, press MENU, or wait 30 seconds.

Dim 4 Offset

Select **Dim 4 Offset**, press ENTER.

Use UP/DOWN button to select a value between -128 and 127, confirm your selection with ENTER.

To exit the offset menu, press MENU, or wait 30 seconds.

Dim 5 Offset

Select **Dim 5 Offset**, press ENTER.

Use UP/DOWN button to select a value between -128 and 127, confirm your selection with ENTER.

To exit the offset menu, press MENU, or wait 30 seconds.

Dim 6 Offset

Select **Dim 6 Offset**, press ENTER.

Use UP/DOWN button to select a value between -128 and 127, confirm your selection with ENTER.

To exit the offset menu, press MENU, or wait 30 seconds.

Dim 7 Offset

Select **Dim 7 Offset**, press ENTER.

Use UP/DOWN button to select a value between -128 and 127, confirm your selection with ENTER.

To exit the offset menu, press MENU, or wait 30 seconds.

Pan

Select **Pan**, press ENTER.

Use UP/DOWN button to select a value between -128 and 127, confirm your selection with ENTER.

To exit the offset menu, press MENU, or wait 30 seconds.

Tilt

Select **Tilt**, press ENTER.

Use UP/DOWN button to select a value between -128 and 127, confirm your selection with ENTER.

To exit the offset menu, press MENU, or wait 30 seconds.

Cyan

Select **Cyan**, press ENTER.

Use UP/DOWN button to select a value between -128 and 127, confirm your selection with ENTER.

To exit the offset menu, press MENU, or wait 30 seconds.

Magenta

Select **Magenta**, press ENTER.

Use UP/DOWN button to select a value between -128 and 127, confirm your selection with ENTER.

To exit the offset menu, press MENU, or wait 30 seconds.

Yellow

Select **Yellow**, press ENTER.

Use UP/DOWN button to select a value between -128 and 127, confirm your selection with ENTER.

To exit the offset menu, press MENU, or wait 30 seconds.

Cto

Select **Cto**, press ENTER.

Use UP/DOWN button to select a value between -128 and 127, confirm your selection with ENTER.

To exit the offset menu, press MENU, or wait 30 seconds.

Color

Select **Color**, press ENTER.

Use UP/DOWN button to select a value between -128 and 127, confirm your selection with ENTER.

To exit the offset menu, press MENU, or wait 30 seconds.

Gobo

Select **Gobo**, press ENTER.

Use UP/DOWN button to select a value between -128 and 127, confirm your selection with ENTER.

To exit the offset menu, press MENU, or wait 30 seconds.

R-Gobo

Select **R-Gobo**, press ENTER.

Use UP/DOWN button to select a value between -128 and 127, confirm your selection with ENTER.

To exit the offset menu, press MENU, or wait 30 seconds.

Gobo 2

Select **Gobo 2**, press ENTER.

Use UP/DOWN button to select a value between -128 and 127, confirm your selection with ENTER.

To exit the offset menu, press MENU, or wait 30 seconds.

Animation

Select **Animation**, press ENTER.

Use UP/DOWN button to select a value between -128 and 127, confirm your selection with ENTER.

To exit the offset menu, press MENU, or wait 30 seconds.

Iris

Select **Iris**, press ENTER.

Use UP/DOWN button to select a value between -128 and 127, confirm your selection with ENTER.

To exit the offset menu, press MENU, or wait 30 seconds.

Prism 1

Select **Prism 1**, press ENTER.

Use UP/DOWN button to select a value between -128 and 127, confirm your selection with ENTER.

To exit the offset menu, press MENU, or wait 30 seconds.

R-Prism 1

Select **R-Prism 1**, press ENTER.

Use UP/DOWN button to select a value between -128 and 127, confirm your selection with ENTER.

To exit the offset menu, press MENU, or wait 30 seconds.

Prism 2

Select **Prism 2**, press ENTER.

Use UP/DOWN button to select a value between -128 and 127, confirm your selection with ENTER.

To exit the offset menu, press MENU, or wait 30 seconds.

R-Prism 2

Select **R-Prism 2**, press ENTER.

Use UP/DOWN button to select a value between -128 and 127, confirm your selection with ENTER.

To exit the offset menu, press MENU, or wait 30 seconds.

Frost 1

Select **Frost 1**, press ENTER.

Use UP/DOWN button to select a value between -128 and 127, confirm your selection with ENTER.

To exit the offset menu, press MENU, or wait 30 seconds.

Frost 2

Select **Frost 2**, press ENTER.

Use UP/DOWN button to select a value between -128 and 127, confirm your selection with ENTER.

To exit the offset menu, press MENU, or wait 30 seconds.

Zoom

Select **Zoom**, press ENTER.

Use UP/DOWN button to select a value between -128 and 127, confirm your selection with ENTER.

To exit the offset menu, press MENU, or wait 30 seconds.

Focus

Select **Focus**, press ENTER.

Use UP/DOWN button to select a value between -128 and 127, confirm your selection with ENTER.

To exit the offset menu, press MENU, or wait 30 seconds.

Blade

Select **Blade**, press ENTER.

Use UP/DOWN button to select a value between -128 and 127, confirm your selection with ENTER.

To exit the offset menu, press MENU, or wait 30 seconds.

Blade Down 1

Select **Blade Down 1**, press ENTER.

Use UP/DOWN button to select a value between -128 and 127, confirm your selection with ENTER.

To exit the offset menu, press MENU, or wait 30 seconds.

Blade Down 2

Select **Blade Down 2**, press ENTER.

Use UP/DOWN button to select a value between -128 and 127, confirm your selection with ENTER.

To exit the offset menu, press MENU, or wait 30 seconds.

Blade Up 1

Select **Blade Up 1**, press ENTER.

Use UP/DOWN button to select a value between -128 and 127, confirm your selection with ENTER.

To exit the offset menu, press MENU, or wait 30 seconds.

Blade Up 2

Select **Blade Up 2**, press ENTER.

Use UP/DOWN button to select a value between -128 and 127, confirm your selection with ENTER.

To exit the offset menu, press MENU, or wait 30 seconds.

Blade Left 1

Select **Blade Left 1**, press ENTER.

Use UP/DOWN button to select a value between -128 and 127, confirm your selection with ENTER.

To exit the offset menu, press MENU, or wait 30 seconds.

Blade Left 2

Select **Blade Left 2**, press ENTER.

Use UP/DOWN button to select a value between -128 and 127, confirm your selection with ENTER.

To exit the offset menu, press MENU, or wait 30 seconds.

Blade Right 1

Select **Blade Right 1**, press ENTER.

Use UP/DOWN button to select a value between -128 and 127, confirm your selection with ENTER.

To exit the offset menu, press MENU, or wait 30 seconds.

Blade Right 2

Select **Blade Right 2**, press ENTER.

Use UP/DOWN button to select a value between -128 and 127, confirm your selection with ENTER.

To exit the offset menu, press MENU, or wait 30 seconds.

7.1 DMX512 Connection

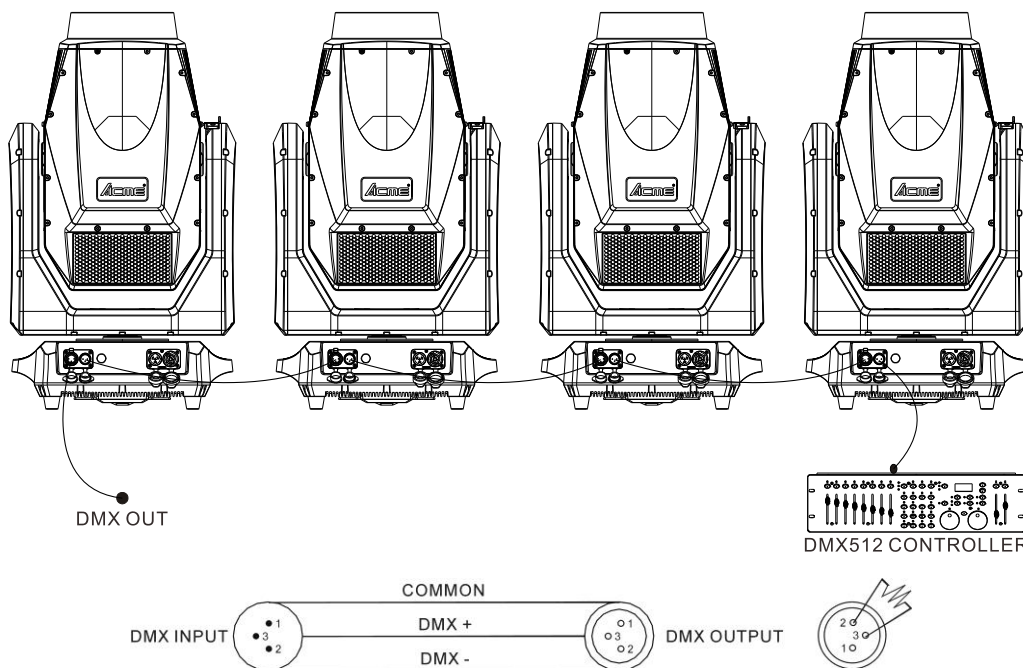

1. At last unit, the DMX cable has to be terminated with a terminator. Solder a 120-ohm 1/4W resistor between pin 2(DMX-) and pin 3(DMX+) into a 3-pin XLR-plug and plug it in the DMX-output of the last unit.
2. Connect the unit together in a “daisy chain” by XLR plug cable from the output of the unit to the input of the next unit. The cable can only be used in series and cannot be connected in parallel. DMX 512 is a very high-speed signal. Inadequate or damaged cables, soldered joints or corroded connectors can easily distort the signal and shut down the system.
3. The DMX output and input connectors are pass-through to maintain the DMX circuit, when one of the units' power is disconnected.
4. Each lighting unit needs to have a DMX address to receive the data by the controller. The address number is between 1-512.
5. The end of the DMX 512 system should be terminated to reduce signal errors.
6. 3 pin XLR connectors are more popular than 5 pins XLR.
 - 3 pin XLR: Pin 1: GND, Pin 2: Negative signal (-), Pin 3: Positive signal (+)
 - 5 pin XLR: Pin 1: GND, Pin 2: Negative signal (-), Pin 3: Positive signal (+), Pin4, Pin5 not used.

7.2 Address Setting

If you use a universal DMX controller to control the units, you have to set DMX address between 1 and 512 so that the units can receive DMX signal.

Press the MENU button to access the control menus, select DMX Settings, press the ENTER button to confirm. Use the UP/DOWN button to select DMX Address, press the ENTER button to confirm, the present address will show on the display. Use the UP/DOWN button to adjust the address between 001 and 512, press the ENTER button to store. To exit the menu, press MENU, or wait 30 seconds.

Please refer to the following diagram to address your DMX512 channel for the first 4 units.

Channel Mode	Unit 1 Address	Unit 2 Address	Unit 3 Address	Unit 4 Address
39 channels	1	40	79	118
30 channels	1	31	61	91
31 channels	1	32	63	94
22 channels	1	23	45	67
40 channels	1	41	81	121

7.3 DMX512 Configuration

Please control the fixture by referring to the configurations below.

Attentions:

- ▶ The unit will maintain the last condition until reset if you cut-off the DMX signal.
- ▶ For the channel Function, keep the value for about 3 seconds, then the corresponding function will take into effect.

39 Channels (Mode 1):

CHANNEL	VALUE	FUNCTION
1	000-255	PAN 0°→540°
2	000-255	PAN FINE
3	000-255	TILT 0°→260°
4	000-255	TILT FINE
5	000-255	PAN/TILT SPEED Fast to Slow
6	000-255	CYAN 0%→100%
7	000-255	MAGENTA 0%→100%
8	000-255	YELLOW 0%→100%
9	000-255	CTO 0%→100%
10	000-007	COLOR Open
	008-018	Color 1
	019-029	Color 2
	030-040	Color 3
	041-051	Color 4
	052-063	Color 5
	064-067	Open
	068-071	Open+Color 1
	072-075	Color 1
	076-079	Color 1+Color 2
	080-083	Color 2
	084-087	Color 2+Color 3
	088-091	Color 3
	092-095	Color 3+Color 4
	096-099	Color 4
	100-103	Color 4+Color 5
	104-107	Color 5
108-111	Color 5+CRI	
112-115	CRI	
116-119	CRI+Open	
120-127	Open	
128-189	Counter-Clockwise Rotation, Fast to Slow	
190-193	Stop	
194-255	Clockwise Rotation, Slow to Fast	
11		GOBO WHEEL 1

	000-007 008-015 016-023 024-031 032-039 040-047 048-055 056-063 064-072 073-081 082-090 091-099 100-108 109-117 118-127 128-189 190-193 194-255	Open Gobo 1 Gobo 2 Gobo 3 Gobo 4 Gobo 5 Gobo 6 Gobo 7 Gobo 1 Shaking, Slow to Fast Gobo 2 Shaking, Slow to Fast Gobo 3 Shaking, Slow to Fast Gobo 4 Shaking, Slow to Fast Gobo 5 Shaking, Slow to Fast Gobo 6 Shaking, Slow to Fast Gobo 7 Shaking, Slow to Fast Clockwise Rotation, Fast to Slow Stop Counter-Clockwise Rotation, Slow to Fast
12	000-127 128-189 190-193 194-255	R-GOBO WHEEL 1 Index 0°→360° Clockwise Rotation, Fast to Slow Stop Counter-Clockwise Rotation, Slow to Fast
13	000-007 008-013 014-019 020-025 026-031 032-037 038-043 044-049 050-055 056-063 064-070 071-077 078-084 085-091 092-098 099-105 106-112 113-119 120-127 128-189 190-193 194-255	GOBO WHEEL 2 Open Gobo 1 Gobo 2 Gobo 3 Gobo 4 Gobo 5 Gobo 6 Gobo 7 Gobo 8 Gobo 9 Gobo 1 Shaking, Slow to Fast Gobo 2 Shaking, Slow to Fast Gobo 3 Shaking, Slow to Fast Gobo 4 Shaking, Slow to Fast Gobo 5 Shaking, Slow to Fast Gobo 6 Shaking, Slow to Fast Gobo 7 Shaking, Slow to Fast Gobo 8 Shaking, Slow to Fast Gobo 9 Shaking, Slow to Fast Counter-Clockwise Rotation, Fast to Slow Stop Clockwise Rotation, Slow to Fast
14		ANIMATION

	000-007 008-129 130-133 134-255	Open Counter-Clockwise Rotation, Fast to Slow Stop Clockwise Rotation, Slow to Fast
15	000-255	IRIS 100%→0%
16	000-007 008-255	PRISM 1(4-facet prism) Close Open
17	000-127 128-189 190-193 194-255	R-PRISM 1 Index 0°→360° Counter-Clockwise Rotation, Fast to Slow Stop Clockwise Rotation, Slow to Fast
18	000-007 008-255	PRISM 2(4-facet linear prism) Close Open
19	000-127 128-189 190-193 194-255	R-PRISM 2 Index 0°→360° Clockwise Rotation, Fast to Slow Stop Counter-Clockwise Rotation, Slow to Fast
20	000-007 008-255	CRI Close Open
21	000-255	FROST1 (Light) 0%→100%
22	000-255	FROST2 (Heavy) 0%→100%
23	000-255	ZOOM Wide→Narrow
24	000-255	ZOOM FINE
25	000-255	FOCUS 0%→100%
26	000-255	FOCUS FINE
27	000-007 008-015 016-131 132-139 140-181 182-189 190-231 232-239 240-247	STROBE Close Open Strobe from Slow to Fast Open Fast Open Slow Close from Slow to Fast Open Fast Close Slow Open from Slow to Fast Open Random Strobe from Slow to Fast

	248-255	Open
28	000-255	DIMMER 0%→100%
29	000-255	DIMMER FINE
30	000-255	BLADE 0°→180°
31	000-255	BLADE DW 1 0%→100%
32	000-255	BLADE DW 2 0%→100%
33	000-255	BLADE UP 1 0%→100%
34	000-255	BLADE UP 2 0%→100%
35	000-255	BLADE LF 1 0%→100%
36	000-255	BLADE LF 2 0%→100%
37	000-255	BLADE RG 1 0%→100%
38	000-255	BLADE RG 2 0%→100%
39		FUNCTION
	000-009	Null
	010-019	Blade Mode: Mode 1
	020-029	Blade Mode: Mode 2
	030-039	Dimmer Curve Square Law
	040-049	Dimmer Curve Inv Square Law
	050-059	Dimmer Curve Linear
	060-069	Dimmer Curve S
	070-079	Cooling Mode: Standard
	080-089	Cooling Mode: Quiet
	090-099	Cooling Mode: Theatre
	100-109	LED Frequency Setting Enable
	110-119	LED Frequency Setting Disable
	120-121	900Hz
	122-123	1000Hz
	124-125	1100Hz
	126-127	1200Hz
	128-129	1300Hz
130-131	1400Hz	
132-133	1500Hz	
134-135	2500Hz	
136-137	4000Hz	
138-139	5000Hz	

140-141	6000Hz
142-143	10KHz
144-145	15KHz
146-147	20KHz
148-149	25KHz
150-159	Null
160-169	Null
170-179	Null
180-189	Dimmer Speed Fast
190-199	Dimmer Speed Smooth
200-209	Reset All
210-219	Reset Effect
220-229	Reset Pan/Tilt
230-231	Gobo Short Cut: Enable
232-233	Gobo Short Cut: Disable
234-235	Color Short Cut: Enable
236-237	Color Short Cut: Disable
238-239	Null
240-245	Null
246-251	Null
252-255	Null

30 Channels (Mode 2):

CHANNEL	VALUE	FUNCTION
1	000-255	PAN 0°→540°
2	000-255	PAN FINE
3	000-255	TILT 0°→260°
4	000-255	TILT FINE
5	000-255	PAN/TILT SPEED Fast to Slow
6	000-255	CYAN 0%→100%
7	000-255	MAGENTA 0%→100%
8	000-255	YELLOW 0%→100%
9	000-255	CTO 0%→100%
10	000-007 008-018	COLOR Open Color 1

	019-029 030-040 041-051 052-063 064-067 068-071 072-075 076-079 080-083 084-087 088-091 092-095 096-099 100-103 104-107 108-111 112-115 116-119 120-127 128-189 190-193 194-255	Color 2 Color 3 Color 4 Color 5 Open Open+Color 1 Color 1 Color 1+Color 2 Color 2 Color 2+Color 3 Color 3 Color 3+Color 4 Color 4 Color 4+Color 5 Color 5 Color 5+CRI CRI CRI+Open Open Counter-Clockwise Rotation, Fast to Slow Stop Clockwise Rotation, Slow to Fast
11	000-007 008-015 016-023 024-031 032-039 040-047 048-055 056-063 064-072 073-081 082-090 091-099 100-108 109-117 118-127 128-189 190-193 194-255	GOBO WHEEL 1 Open Gobo 1 Gobo 2 Gobo 3 Gobo 4 Gobo 5 Gobo 6 Gobo 7 Gobo 1 Shaking, Slow to Fast Gobo 2 Shaking, Slow to Fast Gobo 3 Shaking, Slow to Fast Gobo 4 Shaking, Slow to Fast Gobo 5 Shaking, Slow to Fast Gobo 6 Shaking, Slow to Fast Gobo 7 Shaking, Slow to Fast Clockwise Rotation, Fast to Slow Stop Counter-Clockwise Rotation, Slow to Fast
12	000-127 128-189 190-193 194-255	R-GOBO WHEEL 1 Index 0°→360° Clockwise Rotation, Fast to Slow Stop Counter-Clockwise Rotation, Slow to Fast
13		GOBO WHEEL 2

	000-007 008-013 014-019 020-025 026-031 032-037 038-043 044-049 050-055 056-063 064-070 071-077 078-084 085-091 092-098 099-105 106-112 113-119 120-127 128-189 190-193 194-255	Open Gobo 1 Gobo 2 Gobo 3 Gobo 4 Gobo 5 Gobo 6 Gobo 7 Gobo 8 Gobo 9 Gobo 1 Shaking, Slow to Fast Gobo 2 Shaking, Slow to Fast Gobo 3 Shaking, Slow to Fast Gobo 4 Shaking, Slow to Fast Gobo 5 Shaking, Slow to Fast Gobo 6 Shaking, Slow to Fast Gobo 7 Shaking, Slow to Fast Gobo 8 Shaking, Slow to Fast Gobo 9 Shaking, Slow to Fast Counter-Clockwise Rotation, Fast to Slow Stop Clockwise Rotation, Slow to Fast
14	000-007 008-129 130-133 134-255	ANIMATION Open Counter-Clockwise Rotation, Fast to Slow Stop Clockwise Rotation, Slow to Fast
15	000-255	IRIS 100%→0%
16	000-007 008-255	PRISM 1(4-facet prism) Close Open
17	000-127 128-189 190-193 194-255	R-PRISM 1 Index 0°→360° Counter-Clockwise Rotation, Fast to Slow Stop Clockwise Rotation, Slow to Fast
18	000-007 008-255	PRISM 2(4-facet linear prism) Close Open
19	000-127 128-189 190-193 194-255	R-PRISM 2 Index 0°→360° Clockwise Rotation, Fast to Slow Stop Counter-Clockwise Rotation, Slow to Fast
20	000-007	CRI Close

	008-255	Open
21	000-255	FROST1 (Light) 0%→100%
22	000-255	FROST2 (Heavy) 0%→100%
23	000-255	ZOOM Wide→Narrow
24	000-255	ZOOM FINE
25	000-255	FOCUS 0%→100%
26	000-255	FOCUS FINE
27	000-007 008-015 016-131 132-139 140-181 182-189 190-231 232-239 240-247 248-255	STROBE Close Open Strobe from Slow to Fast Open Fast Open Slow Close from Slow to Fast Open Fast Close Slow Open from Slow to Fast Open Random Strobe from Slow to Fast Open
28	000-255	DIMMER 0%→100%
29	000-255	DIMMER FINE
30	000-009 010-019 020-029 030-039 040-049 050-059 060-069 070-079 080-089 090-099 100-109 110-119 120-121 122-123 124-125 126-127 128-129 130-131	FUNCTION Null Null Null Dimmer Curve Square Law Dimmer Curve Inv Square Law Dimmer Curve Linear Dimmer Curve S Cooling Mode: Standard Cooling Mode: Quiet Cooling Mode: Theatre LED Frequency Setting Enable LED Frequency Setting Disable 900Hz 1000Hz 1100Hz 1200Hz 1300Hz 1400Hz

132-133	1500Hz
134-135	2500Hz
136-137	4000Hz
138-139	5000Hz
140-141	6000Hz
142-143	10KHz
144-145	15KHz
146-147	20KHz
148-149	25KHz
150-159	Null
160-169	Null
170-179	Null
180-189	Dimmer Speed Fast
190-199	Dimmer Speed Smooth
200-209	Reset All
210-219	Reset Effect
220-229	Reset Pan/Tilt
230-231	Gobo Short Cut: Enable
232-233	Gobo Short Cut: Disable
234-235	Color Short Cut: Enable
236-237	Color Short Cut: Disable
238-239	Null
240-245	Null
246-251	Null
252-255	Null

31 Channels (Mode 3):

CHANNEL	VALUE	FUNCTION
1	000-255	PAN 0°→540°
2	000-255	PAN FINE
3	000-255	TILT 0°→260°
4	000-255	TILT FINE
5	000-255	PAN/TILT SPEED Fast to Slow
6	000-255	CYAN 0%→100%
7	000-255	MAGENTA 0%→100%
8	000-255	YELLOW 0%→100%
9	000-255	CTO 0%→100%

10	000-007	COLOR Open
	008-018	Color 1
	019-029	Color 2
	030-040	Color 3
	041-051	Color 4
	052-063	Color 5
	064-067	Open
	068-071	Open+Color 1
	072-075	Color 1
	076-079	Color 1+Color 2
	080-083	Color 2
	084-087	Color 2+Color 3
	088-091	Color 3
	092-095	Color 3+Color 4
	096-099	Color 4
	100-103	Color 4+Color 5
	104-107	Color 5
	108-111	Color 5+CRI
	112-115	CRI
116-119	CRI+Open	
120-127	Open	
128-189	Counter-Clockwise Rotation, Fast to Slow	
190-193	Stop	
194-255	Clockwise Rotation, Slow to Fast	
11	000-255	IRIS 100%→0%
12	000-007 008-255	CRI Close Open
13	000-255	FROST1 (Light) 0%→100%
14	000-255	FROST2 (Heavy) 0%→100%
15	000-255	ZOOM Wide→Narrow
16	000-255	ZOOM FINE
17	000-255	FOCUS 0%→100%
18	000-255	FOCUS FINE
19	000-007 008-015 016-131 132-139	STROBE Close Open Strobe from Slow to Fast Open

	140-181 182-189 190-231 232-239 240-247 248-255	Fast Open Slow Close from Slow to Fast Open Fast Close Slow Open from Slow to Fast Open Random Strobe from Slow to Fast Open
20	000-255	DIMMER 0%→100%
21	000-255	DIMMER FINE
22	000-255	BLADE 0°→180°
23	000-255	BLADE DW 1 0%→100%
24	000-255	BLADE DW 2 0%→100%
25	000-255	BLADE UP 1 0%→100%
26	000-255	BLADE UP 2 0%→100%
27	000-255	BLADE LF 1 0%→100%
28	000-255	BLADE LF 2 0%→100%
29	000-255	BLADE RG 1 0%→100%
30	000-255	BLADE RG 2 0%→100%
31	000-009 010-019 020-029 030-039 040-049 050-059 060-069 070-079 080-089 090-099 100-109 110-119 120-121 122-123 124-125 126-127 128-129	FUNCTION Null Blade Mode: Mode 1 Blade Mode: Mode 2 Dimmer Curve Square Law Dimmer Curve Inv Square Law Dimmer Curve Linear Dimmer Curve S Cooling Mode: Standard Cooling Mode: Quiet Cooling Mode: Theatre LED Frequency Setting Enable LED Frequency Setting Disable 900Hz 1000Hz 1100Hz 1200Hz 1300Hz

130-131	1400Hz
132-133	1500Hz
134-135	2500Hz
136-137	4000Hz
138-139	5000Hz
140-141	6000Hz
142-143	10KHz
144-145	15KHz
146-147	20KHz
148-149	25KHz
150-159	Null
160-169	Null
170-179	Null
180-189	Dimmer Speed Fast
190-199	Dimmer Speed Smooth
200-209	Reset All
210-219	Reset Effect
220-229	Reset Pan/Tilt
230-231	Gobo Short Cut: Enable
232-233	Gobo Short Cut: Disable
234-235	Color Short Cut: Enable
236-237	Color Short Cut: Disable
238-239	Null
240-245	Null
246-251	Null
252-255	Null

22 Channels (Mode 4):

CHANNEL	VALUE	FUNCTION
1	000-255	PAN 0°→540°
2	000-255	PAN FINE
3	000-255	TILT 0°→260°
4	000-255	TILT FINE
5	000-255	PAN/TILT SPEED Fast to Slow
6	000-255	CYAN 0%→100%
7	000-255	MAGENTA 0%→100%
8	000-255	YELLOW 0%→100%

9	000-255	CTO 0%→100%
10	000-007	COLOR Open
	008-018	Color 1
	019-029	Color 2
	030-040	Color 3
	041-051	Color 4
	052-063	Color 5
	064-067	Open
	068-071	Open+Color 1
	072-075	Color 1
	076-079	Color 1+Color 2
	080-083	Color 2
	084-087	Color 2+Color 3
	088-091	Color 3
	092-095	Color 3+Color 4
	096-099	Color 4
	100-103	Color 4+Color 5
	104-107	Color 5
	108-111	Color 5+CRI
	112-115	CRI
116-119	CRI+Open	
120-127	Open	
128-189	Counter-Clockwise Rotation, Fast to Slow	
190-193	Stop	
194-255	Clockwise Rotation, Slow to Fast	
11	000-255	IRIS 100%→0%
12	000-007	CRI Close
	008-255	Open
13	000-255	FROST1 (Light) 0%→100%
14	000-255	FROST2 (Heavy) 0%→100%
15	000-255	ZOOM Wide→Narrow
16	000-255	ZOOM FINE
17	000-255	FOCUS 0%→100%
18	000-255	FOCUS FINE
19	000-007	STROBE Close
	008-015	Open

	016-131 132-139 140-181 182-189 190-231 232-239 240-247 248-255	Strobe from Slow to Fast Open Fast Open Slow Close from Slow to Fast Open Fast Close Slow Open from Slow to Fast Open Random Strobe from Slow to Fast Open
20	000-255	DIMMER 0%→100%
21	000-255	DIMMER FINE
22	000-009 010-019 020-029 030-039 040-049 050-059 060-069 070-079 080-089 090-099 100-109 110-119 120-121 122-123 124-125 126-127 128-129 130-131 132-133 134-135 136-137 138-139 140-141 142-143 144-145 146-147 148-149 150-159 160-169 170-179 180-189 190-199 200-209 210-219 220-229	FUNCTION Null Null Null Dimmer Curve Square Law Dimmer Curve Inv Square Law Dimmer Curve Linear Dimmer Curve S Cooling Mode: Standard Cooling Mode: Quiet Cooling Mode: Theatre LED Frequency Setting Enable LED Frequency Setting Disable 900Hz 1000Hz 1100Hz 1200Hz 1300Hz 1400Hz 1500Hz 2500Hz 4000Hz 5000Hz 6000Hz 10KHz 15KHz 20KHz 25KHz Null Null Null Dimmer Speed Fast Dimmer Speed Smooth Reset All Reset Effect Reset Pan/Tilt

	230-231	Gobo Short Cut: Enable
	232-233	Gobo Short Cut: Disable
	234-235	Color Short Cut: Enable
	236-237	Color Short Cut: Disable
	238-239	Null
	240-245	Null
	246-251	Null
	252-255	Null

40 Channels (Mode 5):

CHANNEL	VALUE	FUNCTION
1	000-255	PAN 0°→540°
2	000-255	PAN FINE
3	000-255	TILT 0°→260°
4	000-255	TILT FINE
5	000-255	PAN/TILT SPEED Fast to Slow
6	000-255	CYAN 0%→100%
7	000-255	MAGENTA 0%→100%
8	000-255	YELLOW 0%→100%
9	000-255	CTO 0%→100%
10	000-007 008-018 019-029 030-040 041-051 052-063 064-067 068-071 072-075 076-079 080-083 084-087 088-091 092-095 096-099	COLOR Open Color 1 Color 2 Color 3 Color 4 Color 5 Open Open+Color 1 Color 1 Color 1+Color 2 Color 2 Color 2+Color 3 Color 3 Color 3+Color 4 Color 4

	100-103 104-107 108-111 112-115 116-119 120-127 128-189 190-193 194-255	Color 4+Color 5 Color 5 Color 5+CRI CRI CRI+Open Open Counter-Clockwise Rotation, Fast to Slow Stop Clockwise Rotation, Slow to Fast
11	000-007 008-015 016-023 024-031 032-039 040-047 048-055 056-063 064-072 073-081 082-090 091-099 100-108 109-117 118-127 128-189 190-193 194-255	GOBO WHEEL 1 Open Gobo 1 Gobo 2 Gobo 3 Gobo 4 Gobo 5 Gobo 6 Gobo 7 Gobo 1 Shaking, Slow to Fast Gobo 2 Shaking, Slow to Fast Gobo 3 Shaking, Slow to Fast Gobo 4 Shaking, Slow to Fast Gobo 5 Shaking, Slow to Fast Gobo 6 Shaking, Slow to Fast Gobo 7 Shaking, Slow to Fast Clockwise Rotation, Fast to Slow Stop Counter-Clockwise Rotation, Slow to Fast
12	000-127 128-189 190-193 194-255	R-GOBO WHEEL 1 Index 0°→360° Clockwise Rotation, Fast to Slow Stop Counter-Clockwise Rotation, Slow to Fast
13	000-255	R-GOBO WHEEL 1 FINE 0%→100%
14	000-007 008-013 014-019 020-025 026-031 032-037 038-043 044-049 050-055 056-063 064-070	GOBO WHEEL 2 Open Gobo 1 Gobo 2 Gobo 3 Gobo 4 Gobo 5 Gobo 6 Gobo 7 Gobo 8 Gobo 9 Gobo 1 Shaking, Slow to Fast

	071-077 078-084 085-091 092-098 099-105 106-112 113-119 120-127 128-189 190-193 194-255	Gobo 2 Shaking, Slow to Fast Gobo 3 Shaking, Slow to Fast Gobo 4 Shaking, Slow to Fast Gobo 5 Shaking, Slow to Fast Gobo 6 Shaking, Slow to Fast Gobo 7 Shaking, Slow to Fast Gobo 8 Shaking, Slow to Fast Gobo 9 Shaking, Slow to Fast Counter-Clockwise Rotation, Fast to Slow Stop Clockwise Rotation, Slow to Fast
15	000-007 008-129 130-133 134-255	ANIMATION Open Counter-Clockwise Rotation, Fast to Slow Stop Clockwise Rotation, Slow to Fast
16	000-255	IRIS 100%→0%
17	000-007 008-255	PRISM 1(4-facet prism) Close Open
18	000-127 128-189 190-193 194-255	R-PRISM 1 Index 0°→360° Counter-Clockwise Rotation, Fast to Slow Stop Clockwise Rotation, Slow to Fast
19	000-007 008-255	PRISM 2(4-facet linear prism) Close Open
20	000-127 128-189 190-193 194-255	R-PRISM 2 Index 0°→360° Clockwise Rotation, Fast to Slow Stop Counter-Clockwise Rotation, Slow to Fast
21	000-007 008-255	CRI Close Open
22	000-255	FROST1 (Light) 0%→100%
23	000-255	FROST2 (Heavy) 0%→100%
24	000-255	ZOOM Wide→Narrow
25	000-255	ZOOM FINE
26		FOCUS

	000-255	0%→100%
27	000-255	FOCUS FINE
28	000-007 008-015 016-131 132-139 140-181 182-189 190-231 232-239 240-247 248-255	STROBE Close Open Strobe from Slow to Fast Open Fast Open Slow Close from Slow to Fast Open Fast Close Slow Open from Slow to Fast Open Random Strobe from Slow to Fast Open
29	000-255	DIMMER 0%→100%
30	000-255	DIMMER FINE
31	000-255	BLADE 0°→180°
32	000-255	BLADE DW 1 0%→100%
33	000-255	BLADE DW 2 0%→100%
34	000-255	BLADE UP 1 0%→100%
35	000-255	BLADE UP 2 0%→100%
36	000-255	BLADE LF 1 0%→100%
37	000-255	BLADE LF 2 0%→100%
38	000-255	BLADE RG 1 0%→100%
39	000-255	BLADE RG 2 0%→100%
40	000-009 010-019 020-029 030-039 040-049 050-059 060-069 070-079 080-089	FUNCTION Null Blade Mode: Mode 1 Blade Mode: Mode 2 Dimmer Curve Square Law Dimmer Curve Inv Square Law Dimmer Curve Linear Dimmer Curve S Cooling Mode: Standard Cooling Mode: Quiet

090-099	Cooling Mode: Theatre
100-109	LED Frequency Setting Enable
110-119	LED Frequency Setting Disable
120-121	900Hz
122-123	1000Hz
124-125	1100Hz
126-127	1200Hz
128-129	1300Hz
130-131	1400Hz
132-133	1500Hz
134-135	2500Hz
136-137	4000Hz
138-139	5000Hz
140-141	6000Hz
142-143	10KHz
144-145	15KHz
146-147	20KHz
148-149	25KHz
150-159	Null
160-169	Null
170-179	Null
180-189	Dimmer Speed Fast
190-199	Dimmer Speed Smooth
200-209	Reset All
210-219	Reset Effect
220-229	Reset Pan/Tilt
230-231	Gobo Short Cut: Enable
232-233	Gobo Short Cut: Disable
234-235	Color Short Cut: Enable
236-237	Color Short Cut: Disable
238-239	Null
240-245	Null
246-251	Null
252-255	Null

08/ Error Information

Error codes are shown continuously in the display when the fixture fails and they will not disappear until the fixture is repaired.

CPU-B/C/D/E/F Error

Check whether the 485 (DATA) leads on the PCB board are installed in place or disconnected.

Check whether the related 485 (DATA) signal circuit on the PCB board is damaged.

Led Temp. Error

Check whether the temperature detecting board is normal.

Check whether the components of the temperature detecting board are damaged.

Check whether the lead on the temperature detecting board is installed in place or disconnected.

LED Timeout Use

LED Too Hot Off

When the fixture temperature reaches 85°C, it will automatically turn off to protect the fixture.

Base Humi. Error

Check whether the humidity sensor is faulty.

Check whether the lead connecting the humidity sensor is installed in place or disconnected.

Head Humi. Error

Check whether the humidity sensor is faulty.

Check whether the lead connecting the humidity sensor is installed in place or disconnected.

Memory. Error

When the memory IC keeps reporting errors, please replace the motherboard.

Base Humi. Too High

Disassemble the housing of the fixture to dehumidify.

Head Humi. Too High

Disassemble the housing of the fixture to dehumidify.

Pan Reset Error

Check whether the position of the pan where the magnet is installed falls off or is damaged.

Check whether there are obstacles in the pan operating range.

Check whether the Hall element on the pan is damaged.

Check whether the lead connecting the Hall element on the pan and the PCB board is in poor contact or disconnected.

Check whether the motor on the pan is damaged.

Check whether the related circuit of the motor drive board on the pan is damage.

Pan Encode Error

Check whether the encoder on the pan is damaged.

Check whether the lead connecting the encoder on the pan and the PCB board is in poor contact or disconnected.

Tilt Reset Error

Check whether the position of the tilt where the magnet is installed falls off or is damaged.

Check whether there are obstacles in the tilt operating range.

Check whether the Hall element on the tilt is damaged.

Check whether the lead connecting the Hall element on the tilt and the PCB board is in poor contact or disconnected.

Check whether the motor on the tilt is damaged.

Check whether the related circuit of the motor drive board on the tilt is damage.

Tilt Encode Error

Check whether the encoder on the tilt is damaged.

Check whether the lead connecting the encoder on the tilt and the PCB board is in poor contact or disconnected.

Cyan Reset Error

Check whether the position of the cyan color wheel where the magnet is installed falls off or is damaged.

Check whether there are obstacles in the cyan color wheel operating range.

Check whether the Hall element on the cyan color wheel is damaged.

Check whether the lead connecting the Hall element on the cyan color wheel and the PCB board is in poor contact or disconnected.

Check whether the motor on the cyan color wheel is damaged.

Check whether the related circuit of the motor drive board on the cyan color wheel is damage.

Magenta Reset Error

Check whether the position of the magenta color wheel where the magnet is installed falls off or is damaged.

Check whether there are obstacles in the magenta color wheel operating range.

Check whether the Hall element on the magenta color wheel is damaged.

Check whether the lead connecting the Hall element on the magenta color wheel and the PCB board is in poor contact or disconnected.

Check whether the motor on the magenta color wheel is damaged.

Check whether the related circuit of the motor drive board on the magenta color wheel is damage.

Yellow Reset Error

Check whether the position of the yellow color wheel where the magnet is installed falls off or is damaged.

Check whether there are obstacles in the yellow color wheel operating range.

Check whether the Hall element on the yellow color wheel is damaged.

Check whether the lead connecting the Hall element on the yellow color wheel and the PCB board is in poor contact or disconnected.

Check whether the motor on the yellow color wheel is damaged.

Check whether the related circuit of the motor drive board on the yellow color wheel is damage.

Cto Reset Error

Check whether the position of the cto where the magnet is installed falls off or is damaged.

Check whether there are obstacles in the cto operating range.

Check whether the Hall element on the cto is damaged.

Check whether the lead connecting the Hall element on the cto and the PCB board is in poor contact or disconnected.

Check whether the motor on the cto is damaged.

Check whether the related circuit of the motor drive board on the cto is damage.

Color Reset Error

Check whether the position of the color wheel where the magnet is installed falls off or is damaged.

Check whether there are obstacles in the color wheel operating range.

Check whether the Hall element on the color wheel is damaged.

Check whether the lead connecting the Hall element on the color wheel and the PCB board is in poor contact or disconnected.

Check whether the motor on the color wheel is damaged.

Check whether the related circuit of the motor drive board on the color wheel is damage.

Gobo1/2 Reset Error

Check whether the position of the gobo wheel 1/2 where the magnet is installed falls off or is damaged.

Check whether there are obstacles in the gobo wheel 1/2 operating range.

Check whether the Hall element on the gobo wheel 1/2 is damaged.

Check whether the lead connecting the Hall element on the gobo wheel 1/2 and the PCB board is in poor contact or disconnected.

Check whether the motor on the gobo wheel 1/2 is damaged.

Check whether the related circuit of the motor drive board on the gobo wheel 1/2 is damage.

R-Gobo1 Reset Error

Check whether the position of the gobo wheel 1 where the magnet is installed falls off or is damaged.

Check whether there are obstacles in the gobo wheel 1 operating range.

Check whether the Hall element on the gobo wheel 1 is damaged.

Check whether the lead connecting the Hall element on the gobo wheel 1 and the PCB board is in poor contact or disconnected.

Check whether the motor on the gobo wheel 1 is damaged.

Check whether the related circuit of the motor drive board on the gobo wheel 1 is damage.

Animation Reset Error

Check whether the position of the animation wheel where the magnet is installed falls off or is damaged.

Check whether there are obstacles in the animation wheel operating range.

Check whether the Hall element on the animation wheel is damaged.

Check whether the lead connecting the Hall element on the animation wheel and the PCB board is in poor contact or disconnected.

Check whether the motor on the animation wheel is damaged.

Check whether the related circuit of the motor drive board on the animation wheel is damage.

Prism1/2 Reset Error

Check whether the position of the prism 1/2 where the magnet is installed falls off or is damaged.

Check whether there are obstacles in the prism 1/2 operating range.

Check whether the Hall element on the prism 1/2 is damaged.

Check whether the lead connecting the Hall element on the prism 1/2 and the PCB board is in poor contact or disconnected.

Check whether the motor on the prism 1/2 is damaged.

Check whether the related circuit of the motor drive board on the prism 1/2 is damage.

R-Prism1/2 Reset Error

Check whether the position of the prism 1/2 where the magnet is installed falls off or is damaged.

Check whether there are obstacles in the prism 1/2 operating range.

Check whether the Hall element on the prism 1/2 is damaged.

Check whether the lead connecting the Hall element on the prism 1/2 and the PCB board is in poor contact or disconnected.

Check whether the motor on the prism 1/2 is damaged.

Check whether the related circuit of the motor drive board on the prism 1/2 is damage.

Zoom Reset Error

Check whether the position of the zoom where the magnet is installed falls off or is damaged.

Check whether there are obstacles in the zoom operating range.

Check whether the Hall element on the zoom is damaged.

Check whether the lead connecting the Hall element on the zoom and the PCB board is in poor contact or disconnected.

Check whether the motor on the zoom is damaged.

Check whether the related circuit of the motor drive board on the zoom is damage.

Focus Reset Error

Check whether the position of the focus where the magnet is installed falls off or is damaged.

Check whether there are obstacles in the focus operating range.

Check whether the Hall element on the focus is damaged.

Check whether the lead connecting the Hall element on the focus and the PCB board is in poor contact or disconnected.

Check whether the motor on the focus is damaged.

Check whether the related circuit of the motor drive board on the focus is damage.

Blade Reset Error

Check whether the position of the blade where the magnet is installed falls off or is damaged.

Check whether there are obstacles in the blade operating range.

Check whether the Hall element on the blade is damaged.

Check whether the lead connecting the Hall element on the blade and the PCB board is in poor contact or disconnected.

Check whether the motor on the blade is damaged.

Check whether the related circuit of the motor drive board on the blade is damage.

BaseFan1/2/3 Start Err

Check whether the fan is not running.

Check whether the fan leads are installed in place or disconnected.

Check whether the fan is damaged.

Check whether there are obstacles in the fan operating range.

ArmFan1 Start Err

- Check whether the fan is not running.
- Check whether the fan leads are installed in place or disconnected.
- Check whether the fan is damaged.
- Check whether there are obstacles in the fan operating range.

HeadFan1/2/3/4/5/6/7/8/9/10/11/12 Start Err

- Check whether the fan is not running.
- Check whether the fan leads are installed in place or disconnected.
- Check whether the fan is damaged.
- Check whether there are obstacles in the fan operating range.

The position of each fan of the fixture:

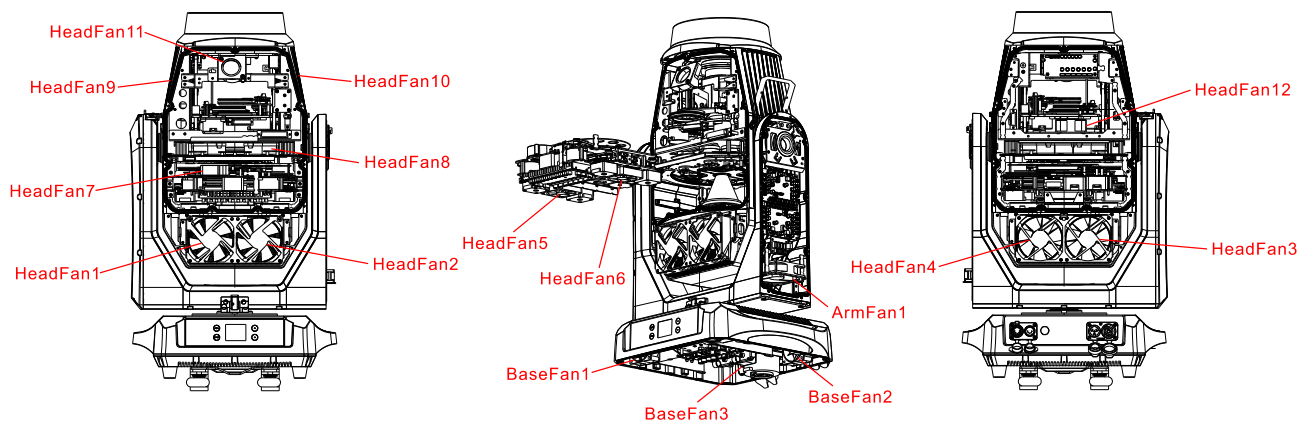

09/ Troubleshooting

Following are a few common problems that may occur during operation. Here are some suggestions for troubleshooting:

A. The unit does not work, no light and the fan does not work

- ▶ Check the connected power.
- ▶ Measure the voltage.
- ▶ Check the power indicator to see whether it can be lit up or not.

B. Not responding to the DMX controller

- ▶ Check whether the DMX connectors and the DMX cables are connected correctly.
- ▶ Check whether the DMX address is correctly set.
- ▶ If the intermittent DMX signal problem occurs, check whether the XLR socket and the signal cable are well connected.
- ▶ Try it with another DMX controller.
- ▶ Check whether the DMX cables run near or alongside to the high-voltage cables, which may damage or interfere with the signal circuit.

C. One of the channels is not working well

- ▶ The stepper motor might be damaged or the cable connected to the PCB might be broken.
- ▶ The motor's drive IC on the PCB might be out of condition.

10/ Fixture Cleaning

It is absolutely essential that the fixture is kept clean to ensure the maximum light-output and allow the fixture to function reliably throughout its life. The fixture must be cleaned regularly to avoid dust, dirt and smoke-fluid residues building up on or within the fixture. The cleaning frequency depends on the application environment. Clean the fixture immediately if the dust enters it to avoid damage to the optical lens due to excessive dust.

- ▶ A soft lint-free cloth moistened with any good glass cleaning fluid is recommended, under no circumstances should solvents be used.
- ▶ Always dry the parts carefully.
- ▶ Clean the external optical lens at least every 20 days.

Declaration of Conformity

We declare that our products (lighting equipments) comply with the following specification and bears CE mark in accordance with the provision of the Electromagnetic Compatibility (EMC) Directive 2014/30/EU.

EN 55032: 2015+A11: 2020; EN 55035: 2017+A11: 2020;
EN IEC 61000-3-2: 2019; EN 61000-3-3: 2013+A1: 2019.

&

Harmonized Standard

EN 60598-2-17: 2018;
EN 60598-1: 2015+A1: 2018.
Safety of household and similar electrical appliances
Part 1: General requirements and tests

Certifications

cETLus Approved (Control #5000057)



www.acmelighting.com