

# Acme®

## *Sunrise*

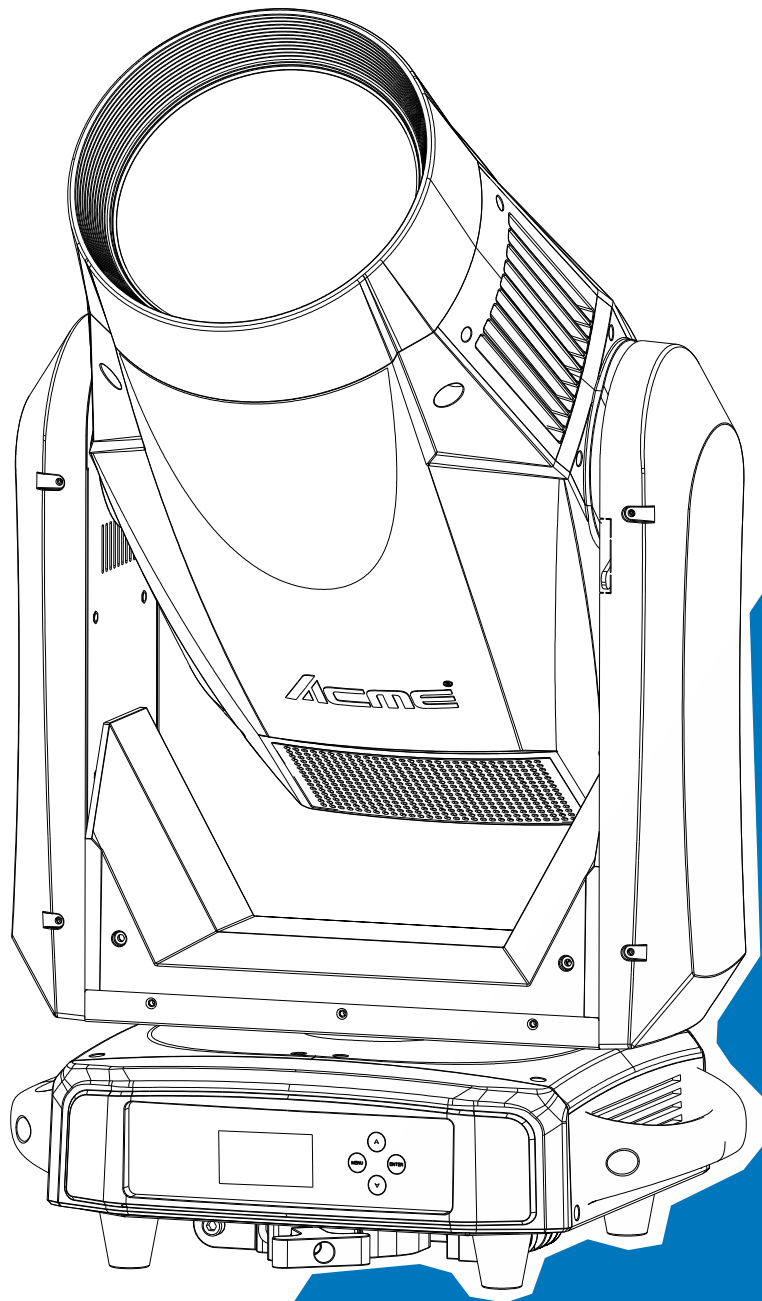

Intertek  
5000057

## User Manual

Please read the instruction carefully before use

## CONTENTS

1. Safety Instructions .....	2
2. Technical Specifications.....	6
3. Control Panel .....	8
4. Fixture Installation .....	9
5. Effect Wheels .....	11
6. How To Set The Unit.....	11
6.1 Main Function .....	11
6.2 Home Position Adjustment.....	19
7. Control By Universal DMX Controller.....	24
7.1 DMX512 Connection .....	24
7.2 Address Setting .....	25
7.3 DMX512 Configuration.....	25
8. Error Information .....	30
9. Troubleshooting .....	34
10. Fixture Cleaning .....	34

## 1. Safety Instructions



Please read the instruction carefully which includes important information about the installation, usage and maintenance.

### WARNING

Please keep this User Manual for future consultation. If you sell the unit to another user, be sure that they also receive this manual.

### Important:

**Damages caused by the disregard of this user manual are not subject to warranty. The dealer will not accept liability for any resulting defects or problems.**

- Unpack and check carefully to ensure that there is no transportation damage before using the unit.
- This product is for indoor use only. Use only in a dry location.
- DO install and operate by qualified operator.
- DO NOT allow children to operate the fixture.
- Use safety chain when fixing the unit. Handle the unit by carrying its base instead of head only.
- The unit must be installed in a location with adequate ventilation, at least 50cm from adjacent surfaces.
- Be sure that no ventilation slots is blocked, otherwise the unit will be overheated.
- Before operation, ensure that you are connecting this product to the proper voltage in accordance with the specifications in this manual or on the product's specification label.
- It's important to ground the yellow/green conductor to earth in order to avoid electric shock.
- Minimum ambient temperature TA: 0°C. Maximum ambient temperature TA: 40°C. Do not operate this product at a lower or higher temperature.
- DO NOT connect the device to any dimmer pack.
- Keep flammable materials away from the fixture while operating to avoid fire hazard.
- Make sure the power cord is not crimped or damaged; replace it immediately if damaged.
- Unit's surface temperature may reach up to 75°C. DO NOT touch the housing bare-handed during its operation.
- Avoid any flammable liquids, water or metal from entering the unit. Once it happens, cut off the mains power immediately.

- DO NOT operate in a dirty or dusty environment. DO clean the fixture regularly.
- DO NOT touch any wire during operation as there might be a hazard of electric shock.
- Avoid entanglement of the power cord with other wires.
- The minimum distance to objects/surface must be more than 3 meters.
- In the event of serious operating problem, stop using the unit immediately.
- Never turn on and off the unit time after time.
- The housing, the lenses, or the ultraviolet filter must be replaced if they are visibly damaged.
- DO NOT open the housing as there are no user serviceable parts inside.
- DO NOT attempt to operate this unit if it becomes damaged. DO NOT attempt any repairs yourself. Repairs carried out by unskilled people can lead to damage or malfunction. Please contact the nearest authorized technical assistance center if needed.
- Disconnect this product from its power source before servicing.
- DO use the original packaging if the device is to be transported.
- Avoid direct eye exposure to the light source while the product is on.
- DO NOT operate this product if you see damage on the housing, shields, or cables. Have the damaged parts replaced by an authorized technician at once.

## 1. Consignes de sécurité



Veillez lire attentivement les instructions qui contiennent des informations importantes sur l'installation, l'utilisation et l'entretien.

### ATTENTION

Veillez conserver ce guide de l'utilisateur pour une consultation future. Si vous vendez l'appareil à un autre utilisateur, assurez-vous qu'il reçoive également ce manuel d'instructions.

### Important:

**Les dommages causés par le non-respect de ce manuel d'utilisation ne sont pas couverts par la garantie. Le revendeur n'acceptera aucune responsabilité pour les défauts ou problèmes qui en résultent.**

- Déballez et vérifiez soigneusement qu'il n'y a pas de dommages dus au transport avant d'utiliser l'appareil.
- Ce produit est destiné à un usage intérieur uniquement. Il doit donc être utilisé uniquement dans un endroit sec.
- L'installation et la mise en fonctionnement doit être effectué par un opérateur qualifié.
- NE PAS permettre aux enfants d'utiliser l'appareil.
- Utilisez une chaîne de sécurité lors de la fixation de l'unité. Manipulez l'appareil en portant sa base au lieu de la tête uniquement.
- L'unité doit être installée dans un endroit avec une ventilation adéquate, à au moins 50cm des surfaces adjacentes.
- Assurez-vous qu'aucune fente d'aération du luminaire n'est obstruée, sinon il risque de surchauffer.
- Avant toute utilisation, assurez-vous que vous connectez ce luminaire à la tension appropriée conformément aux spécifications que vous trouverez dans ce manuel ou sur l'étiquette des spécifications collée sur la base du luminaire.
- Il est important de relier le file jaune/vert à la terre afin d'éviter tout choc électrique.
- Température ambiante minimale TA: 0°C. Température ambiante maximale TA: 40°C. N'utilisez pas ce luminaire à des températures inférieures ou supérieures.
- NE PAS connecter le luminaire à un pack de gradateurs.
- Gardez les matériaux inflammables à l'écart du luminaire pendant le fonctionnement pour éviter tout risque d'incendie.

- Assurez-vous que le cordon d'alimentation n'est pas pincé ou endommagé; remplacez-le immédiatement s'il est endommagé.
- La température de surface de l'unité peut atteindre 75°C. NE PAS toucher les capots à mains nues pendant son fonctionnement.
- Évitez que des liquides inflammables, de l'eau ou du métal ne pénètrent dans l'appareil. Si cela se produit, coupez immédiatement l'alimentation secteur.
- NE PAS utiliser le luminaire dans un environnement sale ou poussiéreux. Cette appareil doit être nettoyer régulièrement.
- NE touchez AUCUN file pendant le fonctionnement car il pourrait y avoir un risque de choc électrique.
- Évitez l'enchevêtrement du cordon d'alimentation avec d'autres fils.
- La distance minimale de projection sur des objets ou sur des surfaces doit être supérieure à 3 mètres.
- En cas de problème de fonctionnement grave, arrêtez immédiatement d'utiliser l'appareil.
- N'allumez et n'éteignez jamais ce luminaire à maintes reprises.
- Le boîtier, les lentilles ou le filtre ultraviolet doivent être remplacés s'ils sont visiblement endommagés.
- NE PAS ouvrir le boîtier car il ne contient aucune pièce réparable par l'utilisateur.
- NE PAS mettre ce luminaire en fonctionnement s'il est endommagé. N'effectuez pas de réparations vous-même. Les réparations ne doivent être effectuées par des personnes non qualifiées, cela peut entraîner des dommages ou des dysfonctionnements. Veuillez contacter le centre d'assistance technique agréé le plus proche si nécessaire.
- Débranchez ce produit du secteur avant de procéder à l'entretien.
- Utiliser l'emballage d'origine si l'appareil doit être transporté.
- Évitez une exposition directe des yeux à la source lumineuse lorsque le produit est allumé.
- N'utilisez PAS ce produit si vous constatez des dommages sur le boîtier, les blindages ou les câbles. Faites remplacer immédiatement les pièces endommagées par un technicien agréé.

## 2. Technical Specifications

### **Power Voltage:**

100-240V~ 50/60Hz

### **Power Consumption:**

1535W

### **Light Source:**

SSL1050AC

### **Color Temperature:**

6500K

### **Zoom Range:**

5°~72°

### **Movement:**

Pan: 540°

Tilt: 270°

Pan/Tilt Resolution: 16 bit

Automatic pan/tilt position correction

Fixation: pan/tilt lock

### **Color Wheel:**

Color Wheel 1: 5 colors plus a soft filter and open with rainbow effect

Color Wheel 2: 6 colors plus open with rainbow effect

### **Control:**

DMX Channel: 27/18 channels

Control Mode: DMX512, RDM, Art-Net, sACN

Firmware Upgrade via DMX link or USB disk

### **Construction:**

Display: LCD display

Battery backup for user setup without mains connection

Data In/Out: 3-pin and 5-pin XLR, RJ45

Power In/Out: Power Connector in/out

Protection Rating: IP20

**Features:**

CRI: Standard mode Ra>70, High CRI mode Ra>90

Switch to high CRI mode with high CRI filter

Linear CMY color mixing

Variable CTO

4 x fast and smooth framing shutters, the position and the angel of each shutter blade can be controlled individually; The framing module can be rotated at ±60 degrees

2 x fixed clamps for 50mm truss; Screw holes for installing clamps are reserved for 70mm truss

**Dimension/Weight:**

465x352x848.4mm, 44.5kgs

18.3"x13.9"x33.4" in, 98lbs

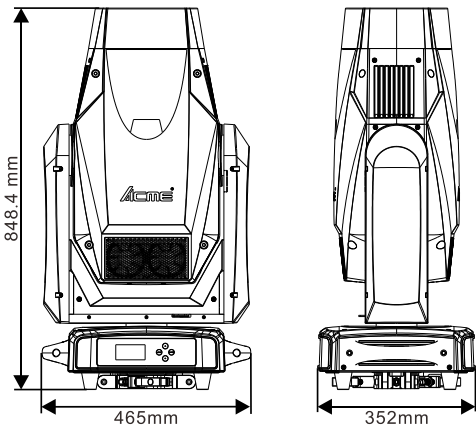

**Photometric Diagram:**

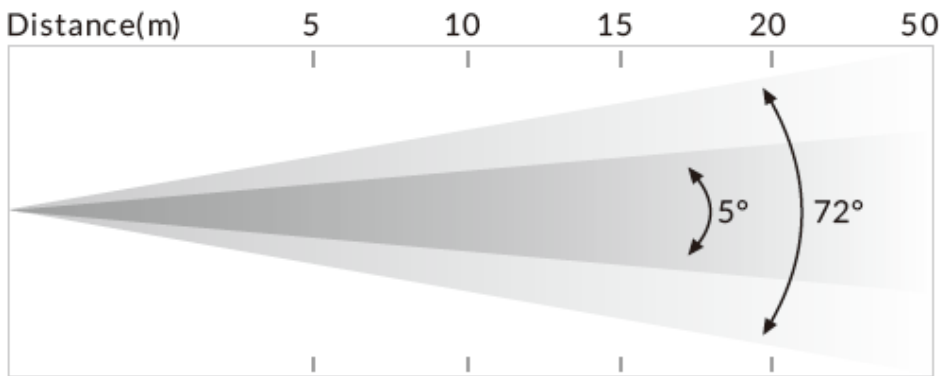

Distance(m)	5	10	15	20	50
5° Lux	165,000	41,500	18,500	10,250	1,650
Diameter(m)	0.43	0.87	1.3	1.75	4.3
72° Lux	5,400	1,350	600	335	54
Diameter(m)	7.98	14.59	21.93	29.25	79.8



### 3. Control Panel

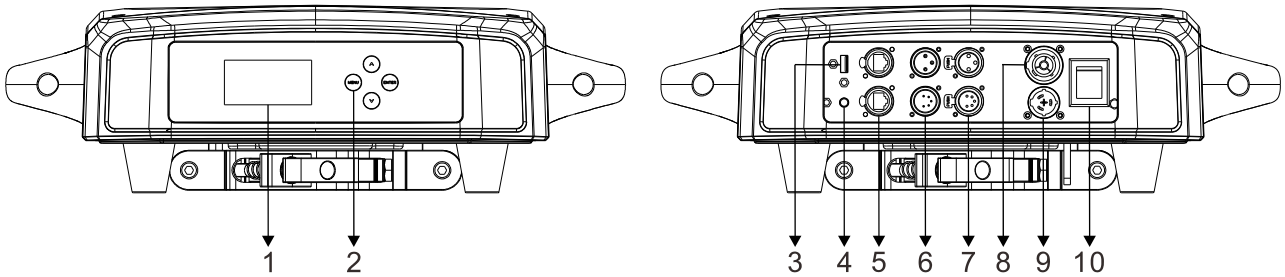

**1. Display:** To show the various menus and the selected function

**2. Button:**

<b>MENU</b>	To enter into move backward or leave the menu
<b>UP</b>	To go backward to move up in the menu
<b>DOWN</b>	To go forward to move down in the menu
<b>ENTER</b>	To perform the desired functions

**3. FIRMWARE UPGRADE:** Used to upgrade fixture's firmware

**4. BATTERY DISPLAY**

**5. ETHERNET:** Transfers fixture's information to a main controller

**6. DMX IN:** For DMX512 operation, use 3/5-pin XLR cable to link the unit and DMX controller

**7. DMX OUT:** For DMX512 operation, use 3/5-pin XLR cable to link the next units

**8. POWERCON OUT:** To connect to the next fixture

**9. POWERCON IN:** To connect to supply power

**10. POWER SWITCH:** Turns on/off the power

## 4. Fixture Installation

DO install and operate by qualified operator. Fixture(s) should be installed in areas outside walking paths, seating areas, or away from areas where unauthorized personnel might reach the fixture by hand. NEVER stand directly below the fixture(s) when rigging, removing or servicing.

Always ensure that the unit is firmly fixed to avoid vibration and slipping off during operation. Ensure that the trussing or area of installation must be able to hold 10 times the weight without any deformation. Always attach a safety cable that can hold at least 12 times the weight of the fixture whenever installing this fixture in a suspended environment to ensure that the fixture will not fall if the clamp fails.

This fixture is fully operational in two different mounting positions: hanging upside-down, or set on a flat level surface. DO NOT mount this fixture sideways on trussing. Always use and install the supplied safety cable as a safety measure to prevent accidental damage and/or injury in the event the clamp fails.

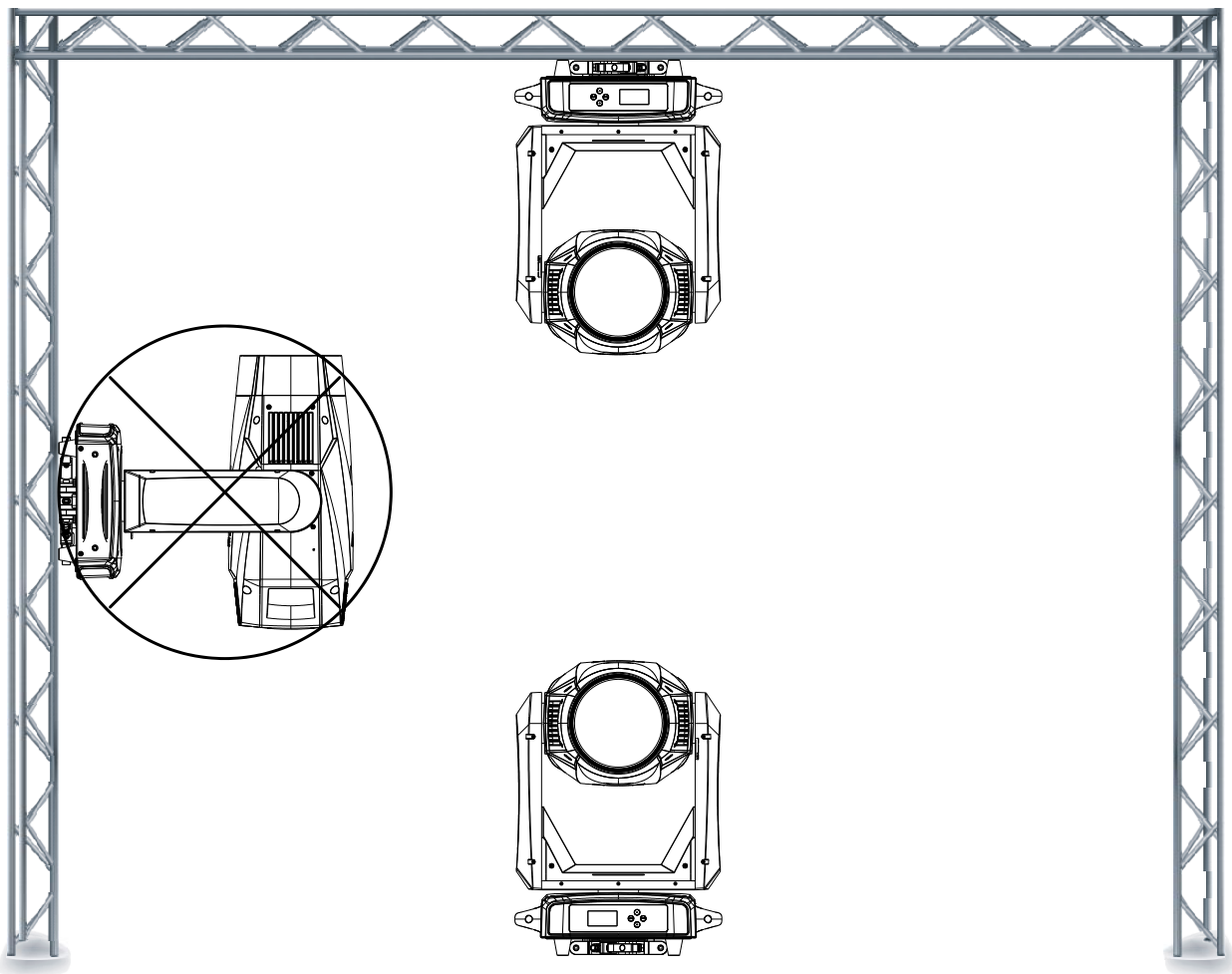

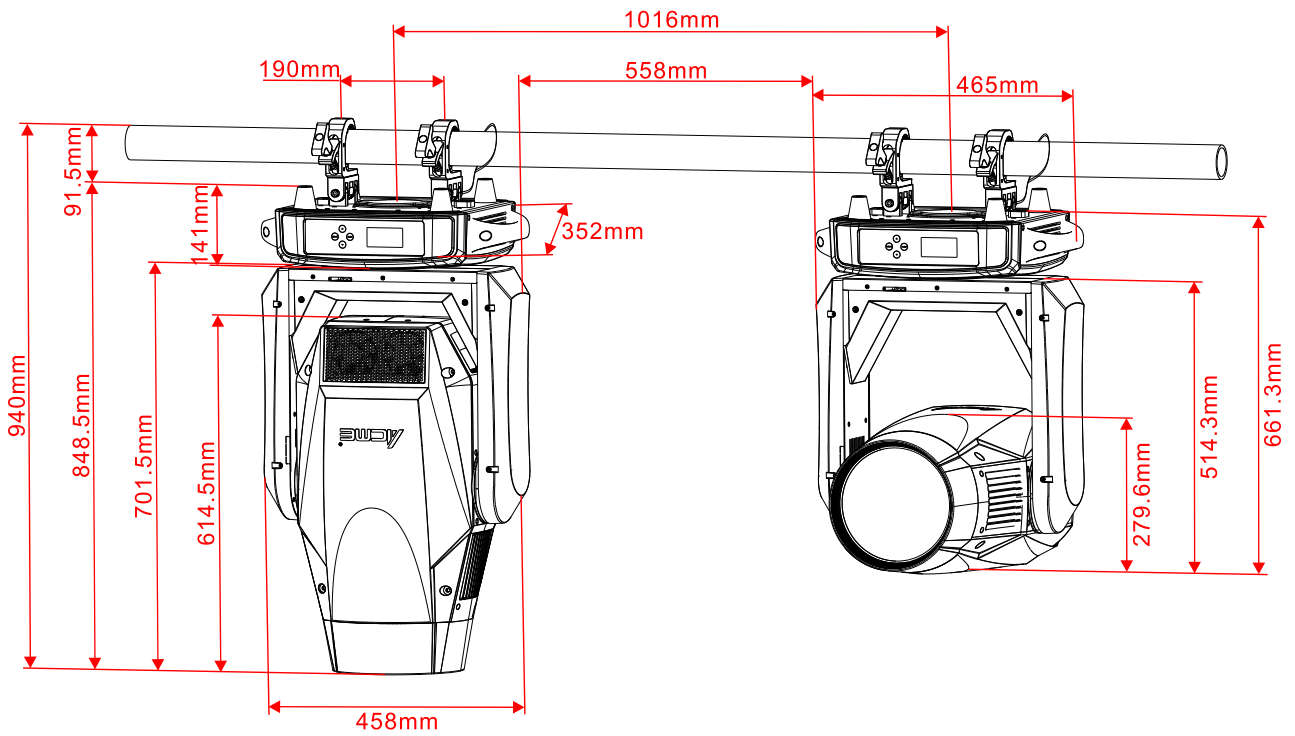

SCREW HOLES (SUITABLE FOR HM12 SCREWS)  
RESERVED FOR CLAMPS FOR TRUSS  
LARGER THAN 50MM IN DIAMETER

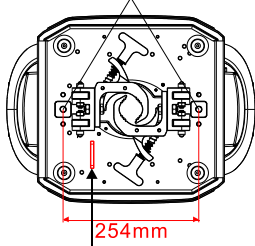

SAFETY CABLE  
ATTACHMENT POINT

CLAMP

HM12\*30 OUTER  
HEXAGON SCREW  
φ12 WASHER

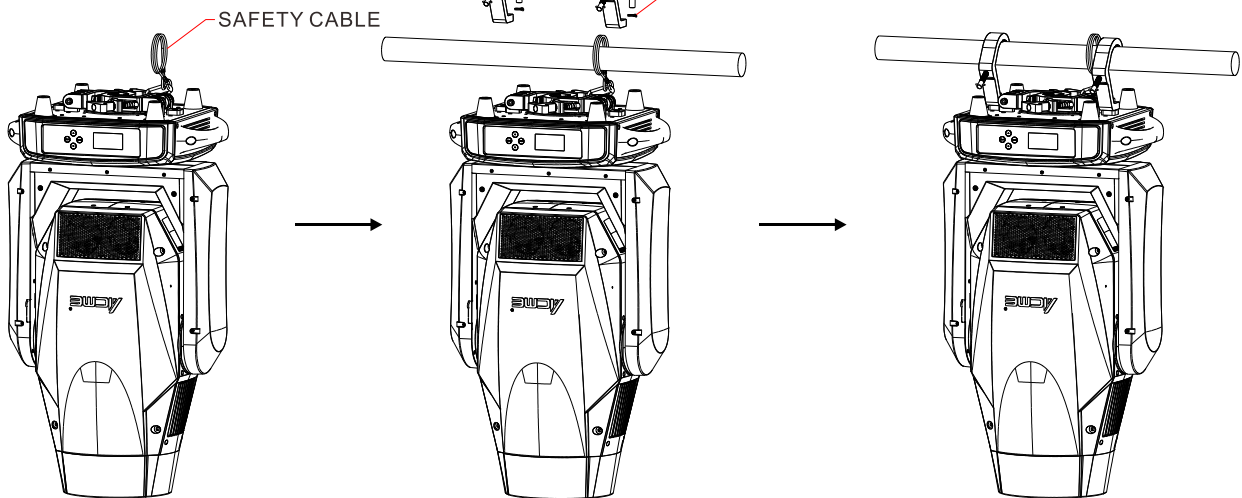

## 5. Effect Wheels

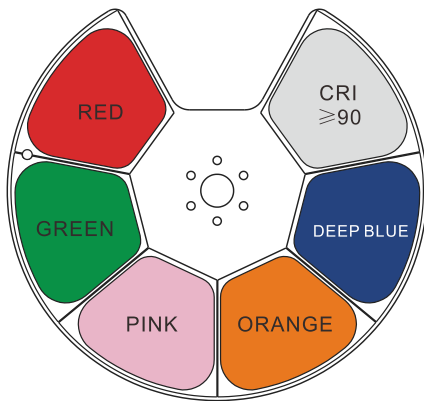

Color Wheel 1

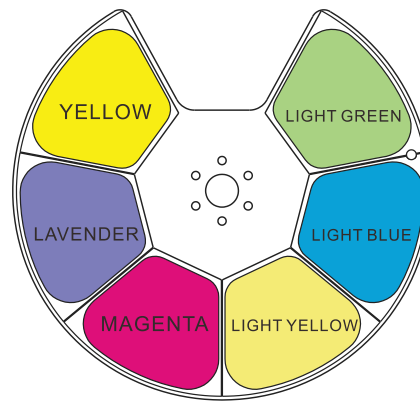

Color Wheel 2

### **DANGER!**

*Install the color wheels with the device switched off only.  
Unplug from mains before changing the color wheels!*

## 6. How To Set The Unit

### 6.1 Main Function

Turn on the unit, press the MENU button into menu mode, and press the UP/DOWN button until the required function is shown on the monitor. Select the function by pressing the ENTER button. Use the UP/DOWN button to choose the submenu, press the ENTER button to store and automatically return to the last menu. Press the MENU button or let the unit idle 30 seconds to exit menu mode.

The main functions are shown below:

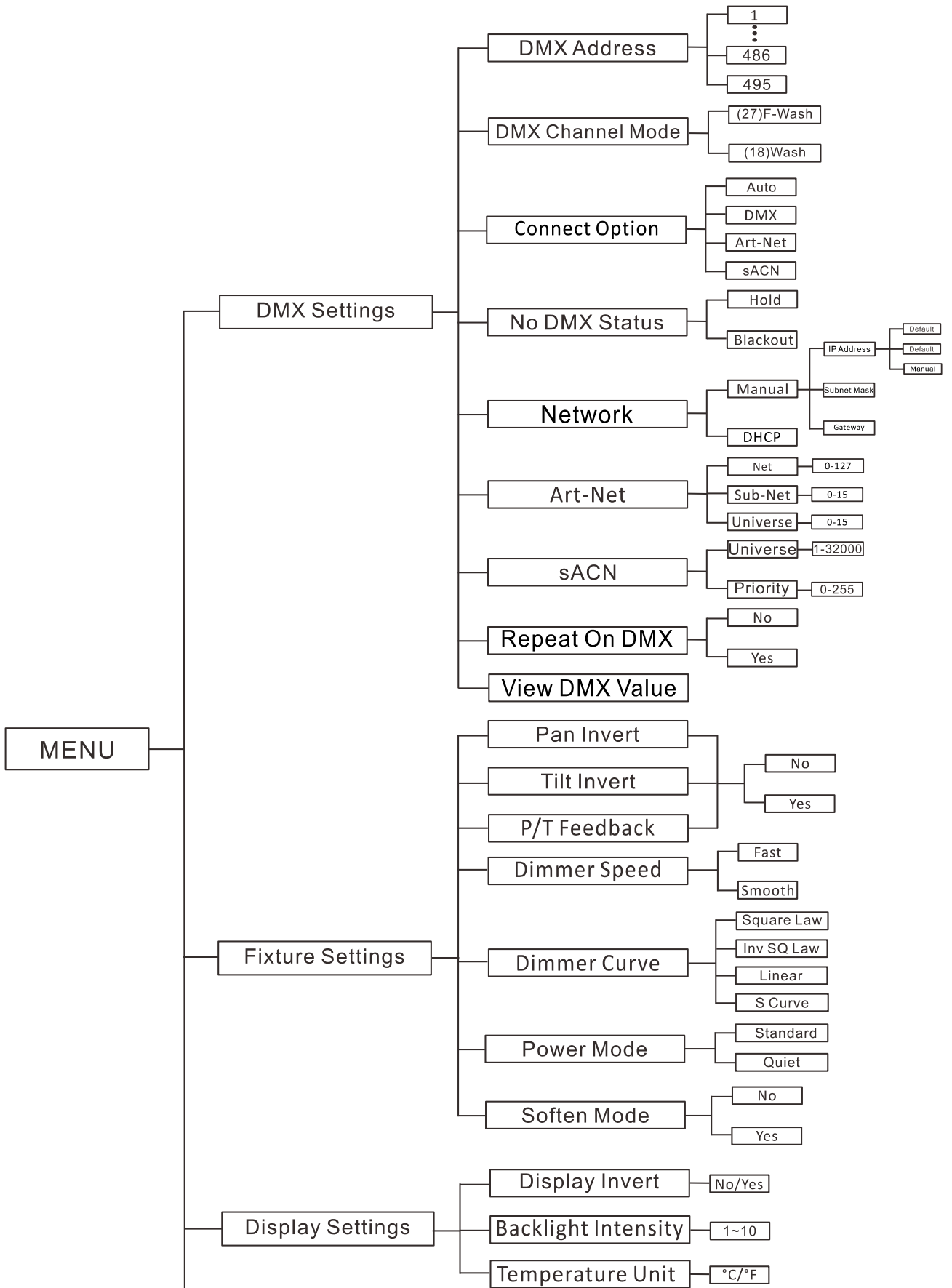

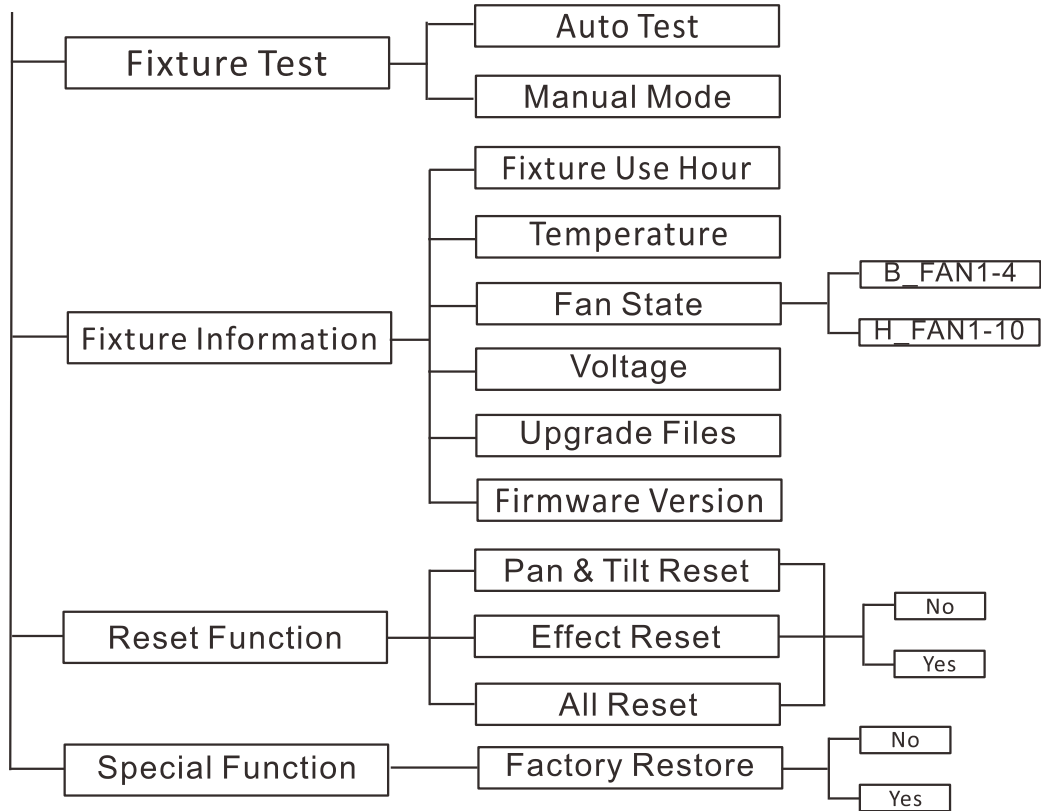

### **DMX Settings**

To select **DMX Settings**, press the **ENTER** button to confirm, use the **UP/DOWN** button to select **DMX Address, DMX Channel Mode, Connect Option, No DMX Status, Network, Art-Net, sACN, Repeat On DMX** or **View DMX Value**.

#### **DMX Address**

To select **DMX Address**, press the **ENTER** button to confirm. Use the **UP/DOWN** button to adjust the address from **1** to **486/495**, press the **ENTER** button to store. Press the **MENU** button back to the last menu or let the unit idle 30 seconds to exit menu mode.

#### **DMX Channel Mode**

To select **DMX Channel Mode**, press the **ENTER** button to confirm. Use the **UP/DOWN** button to select **(27)F-Wash** or **(18)Wash**, press the **ENTER** button to store. Press the **MENU** button back to the last menu or let the unit idle 30 seconds to exit menu mode.

#### **Connect Option**

To select **Connect Option**, press the **ENTER** button to confirm. Use the **UP/DOWN** button to select **Auto, DMX, Art-Net** or **sACN**, press the **ENTER** button to store. Press the **MENU** button back to the last menu or let the unit idle 30 seconds to exit menu mode.

### **No DMX Status**

To select **No DMX Status**, press the **ENTER** button to confirm. Use the **UP/DOWN** button to select **Hold** or **Blackout**, press the **ENTER** button to store. Press the **MENU** button back to the last menu or let the unit idle 30 seconds to exit menu mode.

### **Network**

To select **Network**, press the **ENTER** button to confirm. Use the **UP/DOWN** button to select **Manual** or **DHCP**, press the **ENTER** button to store. To select **Manual**, press the **ENTER** button to confirm. Use the **UP/DOWN** button to select **IP Address**, **Subnet Mask** or **Gateway**, press the **ENTER** button to store. Press the **MENU** button back to the last menu or let the unit idle 30 seconds to exit menu mode.

### **Art-Net**

To select **Art-Net**, press the **ENTER** button to confirm. Use the **UP/DOWN** button to select **Net**, **Sub-Net** or **Universe**, press the **ENTER** button to store. Press the **MENU** button back to the last menu or let the unit idle 30 seconds to exit menu mode.

### **sACN**

To select **sACN**, press the **ENTER** button to confirm. Use the **UP/DOWN** button to select **Universe** or **Priority**, press the **ENTER** button to store. Press the **MENU** button back to the last menu or let the unit idle 30 seconds to exit menu mode.

### **Repeat On DMX**

To select **Repeat On DMX**, press the **ENTER** button to confirm. Use the **UP/DOWN** button to select **No** or **Yes**, press the **ENTER** button to store. Press the **MENU** button back to the last menu or let the unit idle 30 seconds to exit menu mode.

### **View DMX Value**

To select **View DMX Value**, press the **ENTER** button to confirm. Use the **UP/DOWN** button to view the DMX channel value. Press the **MENU** button back to the last menu or let the unit idle 30 seconds to exit menu mode.

## ***Fixture Settings***

To select **Fixture Settings**, press the **ENTER** button to confirm, use the **UP/DOWN** button to select **Pan Invert**, **Tilt Invert**, **P/T Feedback**, **Dimmer Speed**, **Dimmer Curve**, **Power Mode** or **Soften Mode**.

### Pan Invert

To select **Pan Invert**, press the **ENTER** button to confirm. Use the **UP/DOWN** button to select **No** or **Yes**, press the **ENTER** button to store. Press the **MENU** button back to the last menu or let the unit idle 30 seconds to exit menu mode.

### Tilt Invert

To select **Tilt Invert**, press the **ENTER** button to confirm. Use the **UP/DOWN** button to select **No** or **Yes**, press the **ENTER** button to store. Press the **MENU** button back to the last menu or let the unit idle 30 seconds to exit menu mode.

### P/T Feedback

To select **P/T Feedback**, press the **ENTER** button to confirm. Use the **UP/DOWN** button to select **No** (Pan or tilt's position will not feedback while out of step) or **Yes** (Feedback while pan/tilt out of step), press the **ENTER** button to store. Press the **MENU** button back to the last menu or let the unit idle 30 seconds to exit menu mode.

### Dimmer Speed

To select **Dimmer Speed**, press the **ENTER** button to confirm. Use the **DOWN/UP** button to select **Fast** or **Smooth**, press the **ENTER** button to store. Press the **MENU** button back to the last menu or let the unit idle 30 seconds to exit menu mode.

### Dimmer Curve

To select **Dimmer Curve**, press the **ENTER** button to confirm. Use the **DOWN/UP** button to select **Square Law**, **Inv SQ Law**, **Linear** or **S Curve**, press the **ENTER** button to store. Press the **MENU** button back to the last menu or let the unit idle 30 seconds to exit menu mode.

## Dimmer Modes

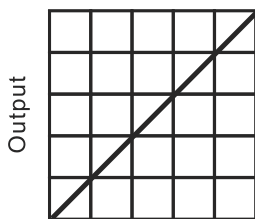

Optically Linear

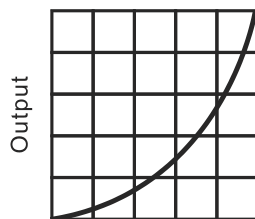

Square Law

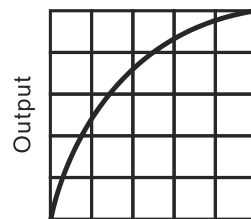

Inverse Square Law

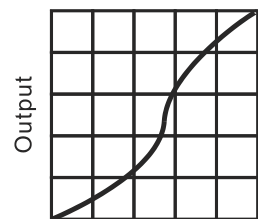

S-curve

### Power Mode

To select **Power Mode**, press the **ENTER** button to confirm. Use the **UP/DOWN** button to select **Standard** or **Quiet**, press the **ENTER** button to store. Press the **MENU** button back to the last menu or let the unit idle 30 seconds to exit menu mode.



### **Soften Mode**

To select **Soften Mode**, press the **ENTER** button to confirm. Use the **UP/DOWN** button to select **No** or **Yes**, press the **ENTER** button to store. Press the **MENU** button back to the last menu or let the unit idle 30 seconds to exit menu mode.

### ***Display Settings***

To select **Display Settings**, press the **ENTER** button to confirm, use the **UP/DOWN** button to select **Display Invert, Backlight Intensity** or **Temperature Unit**.

#### **Display Invert**

Select **Display Invert**, press the **ENTER** button to confirm, present mode will blink on the display, use the **UP/DOWN** button to select **No** (normal display) or **Yes** (invert display), press the **ENTER** button to store. Press the **MENU** button back to the last menu or let the unit idle 30 seconds to exit menu mode.

#### **Backlight Intensity**

Select **Backlight Intensity**, press the **ENTER** button to confirm, present mode will blink on the display, use the **UP/DOWN** button to adjust value from **1** to **10**, press the **ENTER** button to store. Press the **MENU** button back to the last menu or let the unit idle 30 seconds to exit menu mode.

#### **Temperature Unit**

Select **Temperature Unit**, press the **ENTER** button to confirm, present mode will blink on the display, use the **UP/DOWN** button to select **°C** or **°F**, press the **ENTER** button to store. Press the **MENU** button back to the last menu or let the unit idle 30 seconds to exit menu mode.

### ***Fixture Test***

To select **Fixture Test**, press the **ENTER** button to confirm, use the **UP/DOWN** button to select **Auto Test** or **Manual Mode**.

#### **Auto Test**

Select **Auto Test**, press the **ENTER** button to confirm, the unit will run built-in programs to automatically test its functions. Press the **MENU** button back to the last menu or exit menu mode after auto test.

## **Manual Mode**

Select **Manual Mode**, press the **ENTER** button to confirm, the present channel will show on the display, use the **UP/DOWN** button to select channel, press the **ENTER** button to confirm, then use the **UP** and **DOWN** button to adjust the value, press the **ENTER** button to store, the fixture will run as the channel value indicates. Press the **MENU** button back to the last menu or exit menu mode idling 30 seconds.

(All channels value will become 0 after exiting Manual Mode menu)

## ***Fixture Information***

To select **Fixture Information**, press the **ENTER** button to confirm, use the **UP/DOWN** button to select **Fixture Use Hour, Temperature, Fan State, Voltage, Upgrade Files** or **Firmware Version**.

### **Fixture Use Hour**

Select **Fixture Use Hour**, press the **ENTER** button to confirm, fixture use hour will show on the display, press the **MENU** button to exit.

### **Temperature**

Select **Temperature**, press the **ENTER** button to confirm, fixture temperature will show on the display, press the **MENU** button to exit.

### **Fan State**

Select **Fan State**, press the **ENTER** button to confirm, fan state will show on the display, press the **MENU** button to exit.

### **Voltage**

Select **Voltage**, press the **ENTER** button to confirm, fixture voltage will show on the display, press the **MENU** button to exit.

### **Upgrade Files**

Select **Upgrade Files**, press the **ENTER** button to confirm, fixture upgrade files will show on the display, press the **MENU** button to exit.

### **Firmware Version**

Select **Firmware Version**, press the **ENTER** button to confirm, firmware version will show on the display, press the **MENU** button back to exit.

## ***Reset Function***

To select **Reset Function**, press the **ENTER** button to confirm, use the **UP/DOWN** button to select **Pan & Tilt Reset**, **Effect Reset** or **All Reset**.

### **Pan & Tilt Reset**

Select **Pan & Tilt Reset**, press the **ENTER** button to confirm, use the **UP/DOWN** button to select **No** (normal) or **Yes** (the unit will run built-in program to reset pan and tilt to their home positions), press the **ENTER** button to store. Press the **MENU** button to exit.

### **Effect Reset**

Select **Effect Reset**, press the **ENTER** button to confirm, use the **UP/DOWN** button to select **No** or **Yes** (the unit will run built-in program to reset effect to their home positions), press the **ENTER** button to store. Press the **MENU** button to exit.

### **All Reset**

Select **All Reset**, press the **ENTER** button to confirm, use the **UP/DOWN** button to select **No** or **Yes** (the unit will run built-in program to reset all motors to their home positions), press **ENTER** button to store. Press the **MENU** button to exit.

## ***Special Function***

### **Factory Restore**

Select **Factory Restore**, press the **ENTER** button to confirm, use the **UP/DOWN** button to select **No** (normal) or **Yes** (the fixture will reset to factory settings), press **ENTER** button to store. Press the **MENU** button to exit.

## ***RDM FUNCTIONS***

Select the MANUFACTURER menu to display the manufacturer of the fixture.

Select the SOFTWARE VERSION menu and the program version number of the fixture will be displayed.

Select the DMX START ADDRESS menu to change the DMX 512 address (001-512).

Select the DEVICE MODEL DESCRIPTION menu to display the model of the fixture.

Select the DEVICE LABEL menu to change the model of the fixture.

Select the DMX PERSONALITY menu to set the channel mode of the fixture (27/18 channel).

Select the DMX PERSONALITY DESCRIPTION menu to display the current channel mode of the fixture.

Select the DEVICE HOURS menu to display the running time of the fixture.

Select the PAN INVERT menu and the fixture will run the pan invert mode.

Select the TILT INVERT menu and the fixture will run the tilt invert mode.

Select the RESET DEVICE menu, the WARM RESET/COLD RESET option will be displayed. When WARM RESET is selected, the fixture will start a warm reset, and exit when COLD RESET is selected.

## **6.2 Home Position Adjustment**

Press the MENU button into menu mode, then press the ENTER button for about 3 seconds into offset mode to adjust the home position. Select the function by pressing the ENTER button. Use the UP/DOWN button to choose the submenu, press the ENTER button to store and automatically return to the last menu. Press MENU button to exit.

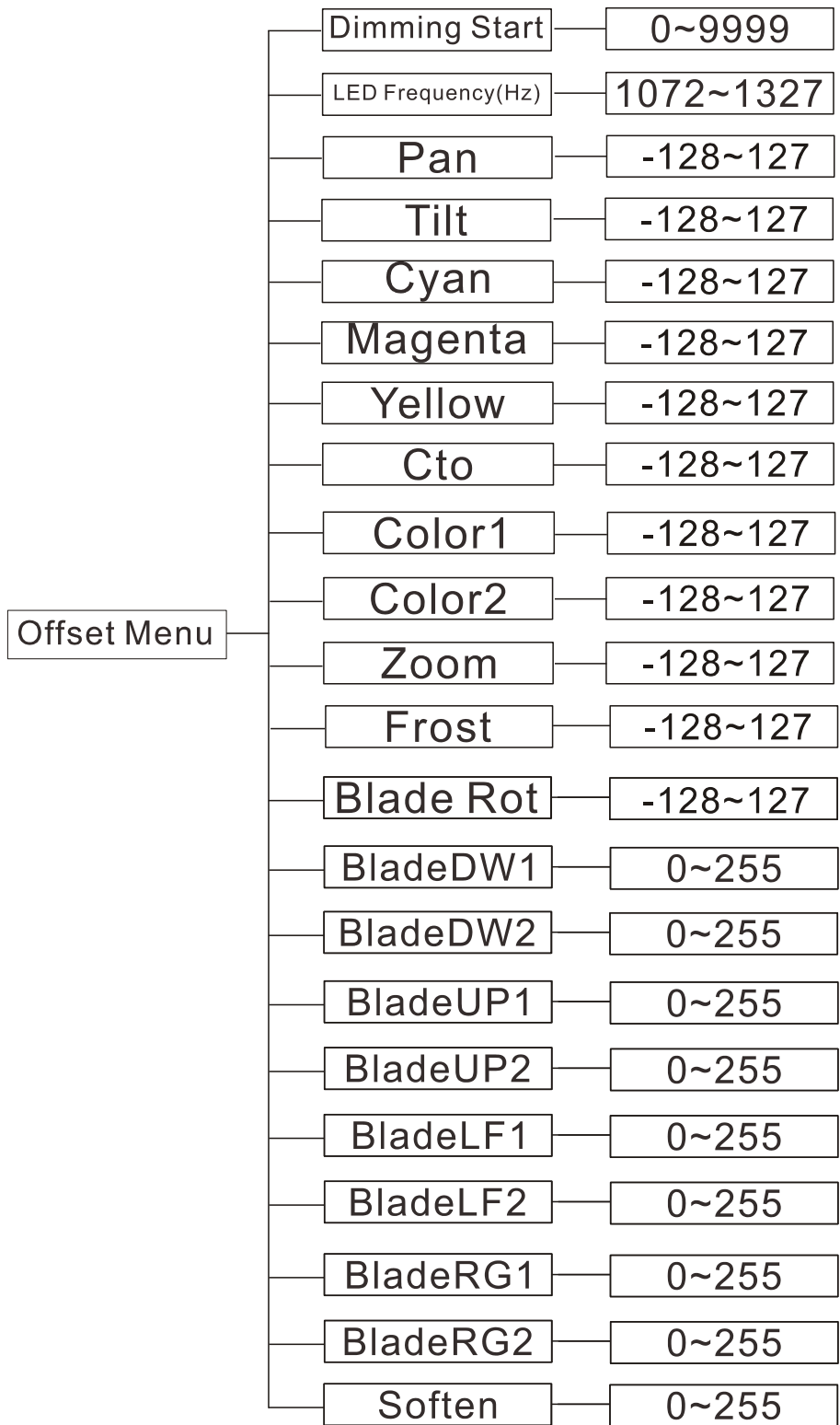

### Dimming Start

Enter offset mode, Select **Dimming Start**, press the **ENTER** button to confirm, the present position will blink on the display, use the **UP/DOWN** button to offset the value from 0 to 9999, press the **ENTER** button to store. Press the **MENU** button to exit.

### **LED Frequency(Hz)**

Enter offset mode, Select **LED Frequency(Hz)**, press the **ENTER** button to confirm, the present position will blink on the display, use the **UP/DOWN** button to offset the value from 1072 to 1327, press the **ENTER** button to store. Press the **MENU** button to exit.

### **Pan**

Enter offset mode, Select **Pan**, press the **ENTER** button to confirm, the present position will blink on the display, use the **UP/DOWN** button to offset the value from -128 to 127, press the **ENTER** button to store. Press the **MENU** button to exit.

### **Tilt**

Enter offset mode, Select **Tilt**, press the **ENTER** button to confirm, the present position will blink on the display, use the **UP/DOWN** button to offset the value from -128 to 127, press the **ENTER** button to store. Press the **MENU** button to exit.

### **Cyan**

Enter offset mode, Select **Cyan**, press the **ENTER** button to confirm, the present position will blink on the display, use the **UP/DOWN** button to offset the value from -128 to 127, press the **ENTER** button to store. Press the **MENU** button to exit.

### **Magenta**

Enter offset mode, Select **Magenta**, press the **ENTER** button to confirm, the present position will blink on the display, use the **UP/DOWN** button to offset the value from -128 to 127, press the **ENTER** button to store. Press the **MENU** button to exit.

### **Yellow**

Enter offset mode, Select **Yellow**, press the **ENTER** button to confirm, the present position will blink on the display, use the **UP/DOWN** button to offset the value from -128 to 127, press the **ENTER** button to store. Press the **MENU** button to exit.

### **Cto**

Enter offset mode, Select **Cto**, press the **ENTER** button to confirm, the present position will blink on the display, use the **UP/DOWN** button to offset the value from -128 to 127, press the **ENTER** button to store. Press the **MENU** button to exit.

### **Color1**

Enter offset mode, Select **Color1**, press the **ENTER** button to confirm, the present position will blink on the display, use the **UP/DOWN** button to offset the value from -128 to 127, press the **ENTER** button to store. Press the **MENU** button to exit.

## **Color2**

Enter offset mode, Select **Color2**, press the **ENTER** button to confirm, the present position will blink on the display, use the **UP/DOWN** button to offset the value from -128 to 127, press the **ENTER** button to store. Press the **MENU** button to exit.

## **Zoom**

Enter offset mode, Select **Zoom**, press the **ENTER** button to confirm, the present position will blink on the display, use the **UP/DOWN** button to offset the value from -128 to 127, press the **ENTER** button to store. Press the **MENU** button to exit.

## **Frost**

Enter offset mode, Select **Frost**, press the **ENTER** button to confirm, the present position will blink on the display, use the **UP/DOWN** button to offset the value from -128 to 127, press the **ENTER** button to store. Press the **MENU** button to exit.

## **Blade Rot**

Enter offset mode, Select **Blade Rot**, press the **ENTER** button to confirm, the present position will blink on the display, use the **UP/DOWN** button to offset the value from -128 to 127, press the **ENTER** button to store. Press the **MENU** button to exit.

## **BladeDW1**

Enter offset mode, Select **BladeDW1**, press the **ENTER** button to confirm, the present position will blink on the display, use the **UP/DOWN** button to offset the value from 0 to 255, press the **ENTER** button to store. Press the **MENU** button to exit.

## **BladeDW2**

Enter offset mode, Select **BladeDW2**, press the **ENTER** button to confirm, the present position will blink on the display, use the **UP/DOWN** button to offset the value from 0 to 255, press the **ENTER** button to store. Press the **MENU** button to exit.

## **BladeUP1**

Enter offset mode, Select **BladeUP1**, press the **ENTER** button to confirm, the present position will blink on the display, use the **UP/DOWN** button to offset the value from 0 to 255, press the **ENTER** button to store. Press the **MENU** button to exit.

## **BladeUP2**

Enter offset mode, Select **BladeUP2**, press the **ENTER** button to confirm, the present position will blink on the display, use the **UP/DOWN** button to offset the value from 0 to 255, press the **ENTER** button to store. Press the **MENU** button to exit.

### **BladeLF1**

Enter offset mode, Select **BladeLF1**, press the **ENTER** button to confirm, the present position will blink on the display, use the **UP/DOWN** button to offset the value from 0 to 255, press the **ENTER** button to store. Press the **MENU** button to exit.

### **BladeLF2**

Enter offset mode, Select **BladeLF2**, press the **ENTER** button to confirm, the present position will blink on the display, use the **UP/DOWN** button to offset the value from 0 to 255, press the **ENTER** button to store. Press the **MENU** button to exit.

### **BladeRGF1**

Enter offset mode, Select **BladeRG1**, press the **ENTER** button to confirm, the present position will blink on the display, use the **UP/DOWN** button to offset the value from 0 to 255, press the **ENTER** button to store. Press the **MENU** button to exit.

### **BladeRG2**

Enter offset mode, Select **BladeRG2**, press the **ENTER** button to confirm, the present position will blink on the display, use the **UP/DOWN** button to offset the value from 0 to 255, press the **ENTER** button to store. Press the **MENU** button to exit.

### **Soften**

Enter offset mode, Select **Soften**, press the **ENTER** button to confirm, the present position will blink on the display, use the **UP/DOWN** button to offset the value from 0 to 255, press the **ENTER** button to store. Press the **MENU** button to exit.



## 7. Control By Universal DMX Controller

### 7.1 DMX512 Connection

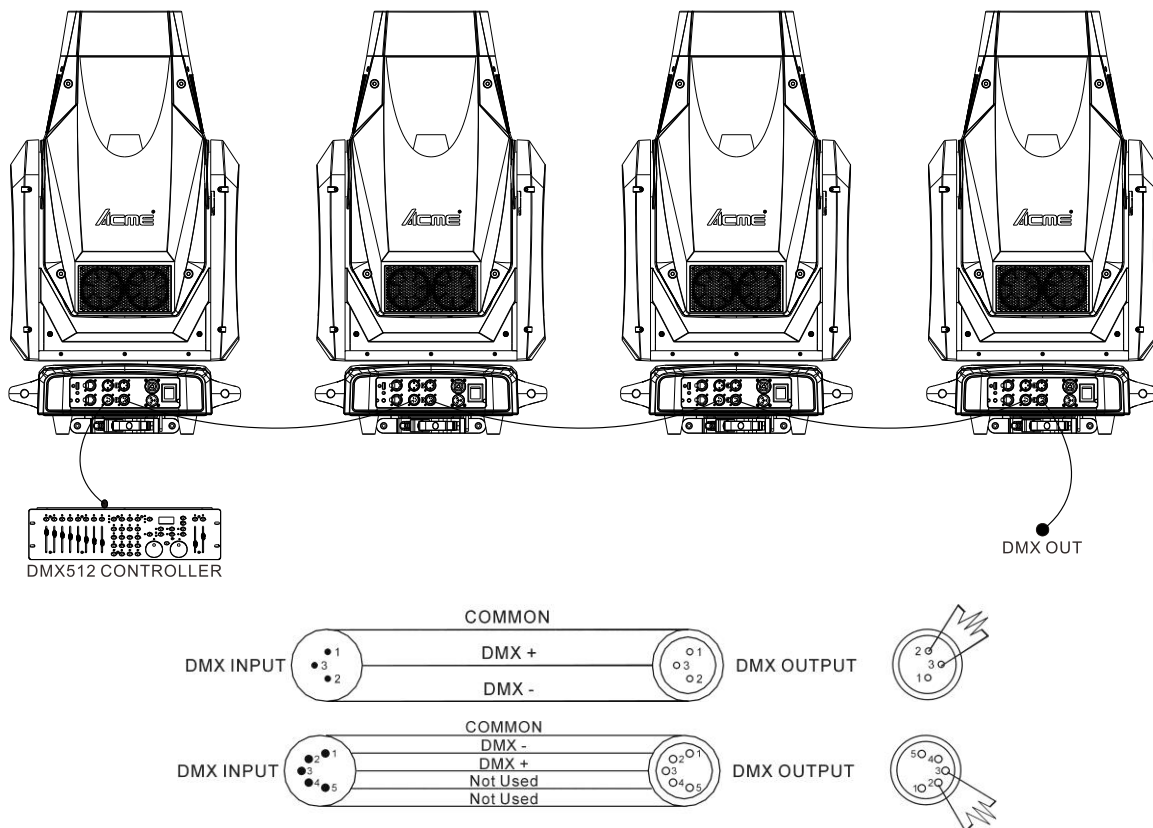

1. At last unit, the DMX cable has to be terminated with a terminator. Solder a 120-ohm 1/4W resistor between pin 2(DMX-) and pin 3(DMX+) into a 3-pin XLR-plug and plug it in the DMX-output of the last unit.
2. Connect the unit together in a “daisy chain” by XLR plug cable from the output of the unit to the input of the next unit. The cable can only be used in series and cannot be connected in parallel. DMX 512 is a very high-speed signal. Inadequate or damaged cables, soldered joints or corroded connectors can easily distort the signal and shut down the system.
3. The DMX output and input connectors are pass-through to maintain the DMX circuit, when one of the units’ power is disconnected.
4. Each lighting unit needs to have a DMX address to receive the data by the controller. The address number is between 1-512.
5. The end of the DMX 512 system should be terminated to reduce signal errors.
6. 3 pin XLR connectors are more popular than 5 pins XLR.
  - 3 pin XLR: Pin 1: GND, Pin 2: Negative signal (-), Pin 3: Positive signal (+)
  - 5 pin XLR: Pin 1: GND, Pin 2: Negative signal (-), Pin 3: Positive signal (+), Pin4, Pin5 not used.

## 7.2 Address Setting

If you use a universal DMX controller to control the units, you have to set DMX address from 1 to 512 so that the units can receive DMX signal.

Press the MENU button to enter menu mode, select DMX Settings, press the ENTER button to confirm, use the UP/DOWN button to select DMX Address, press the ENTER button to confirm, the present address will blink in the display, use the UP/DOWN button to adjust the address from 001 to 512, press the ENTER button to store. Press the MENU button back to the last menu or let the unit idle 30 seconds to exit menu mode.

Please refer to the following diagram to address your DMX512 channel for the first 4 units.

Channel mode	Unit 1 Address	Unit 2 Address	Unit 3 Address	Unit 4 Address
27 channels	1	28	55	82
18 channels	1	19	37	55

## 7.3 DMX512 Configuration

Please control the fixture by referring to the configurations below

### Attentions:

1. The unit will maintain the last condition until reset if you cut-off the DMX signal.
2. For the channel Function, keep the value for about 3 seconds, then the corresponding function will take into effect.

### 27 Channels (Mode 1):

CHANNEL	VALUE	FUNCTION
1	000-255	<b>Pan</b> 0°→540°
2	000-255	<b>Pan Fine</b>
3	000-255	<b>Tilt</b> 0°→270°
4	000-255	<b>Tilt Fine</b>
5	000-255	<b>P/T Speed</b> Fast to Slow
6	000-255	<b>Cyan</b> 0%→100%
7	000-255	<b>Magenta</b> 0%→100%

<b>8</b>	000-255	<b>Yellow</b> 0%→100%
<b>9</b>	000-255	<b>CTO</b> 0%→100%
<b>10</b>	000-009 010-018 019-027 028-036 037-045 046-063 064-127 128-189 190-193 194-255	<b>Color 1</b> Open Color1 Color2 Color3 Color4 Color5 Color Index Rotate Fast to Slow Stop Rotate Slow to Fast
<b>11</b>	000-009 010-018 019-027 028-036 037-045 046-054 055-063 064-127 128-189 190-193 194-255	<b>Color 2</b> Open Color1 Color2 Color3 Color4 Color5 Color6 Color Index Rotate Fast to Slow Stop Rotate Slow to Fast
<b>12</b>	000-007 008-255	<b>CRI</b> Close Open
<b>13</b>	000-255	<b>Frost</b> 0%→100%
<b>14</b>	000-255	<b>Zoom</b> 72°→5°
<b>15</b>	000-007 008-015 016-131 132-139 140-181 182-189 190-231 232-239 240-247 248-255	<b>Strobe</b> Close Open Strobe Slow to Fast Open Fast Open Slow Close Open Fast Close Slow Open Open Random Strobe Open
<b>16</b>		<b>Dimmer</b>

	000-255	0%→100%
<b>17</b>	000-255	<b>Dimmer Fine</b>
<b>18</b>	000-255	<b>Blade</b> 0°-180°
<b>19</b>	000-255	<b>BladeDW1</b> 0%→100%
<b>20</b>	000-255	<b>BladeDW2</b> 0%→100%
<b>21</b>	000-255	<b>BladeUP1</b> 0%→100%
<b>22</b>	000-255	<b>BladeUP2</b> 0%→100%
<b>23</b>	000-255	<b>BladeLF1</b> 0%→100%
<b>24</b>	000-255	<b>BladeLF2</b> 0%→100%
<b>25</b>	000-255	<b>BladeRG1</b> 0%→100%
<b>26</b>	000-255	<b>BladeRG2</b> 0%→100%
<b>27</b>	000-029 030-039 040-049 050-059 060-069 070-079 080-089 090-099 100-109 110-119 120-129 130-139 140-149 150-159 160-169 170-179 180-189 190-199 200-209 210-219 220-229 230-255	<b>Function</b> Null Dimmer Curve Square Law Dimmer Curve INV Square Law Dimmer Curve Linear Dimmer Curve S Soften Mode On Soften Mode Off Null LED Frequency Setting Enable LED Frequency Setting Disable Null Null Null Null Null Null Dimmer Speed Fast Dimmer Speed Smooth Reset All Reset Effect Reset Pan/Tilt Null

18 Channels (Mode 2):

CHANNEL	VALUE	FUNCTION
1	000-255	<b>Pan</b> 0°→540°
2	000-255	<b>Pan Fine</b>
3	000-255	<b>Tilt</b> 0°→270°
4	000-255	<b>Tilt Fine</b>
5	000-255	<b>P/T Speed</b> Fast to Slow
6	000-255	<b>Cyan</b> 0%→100%
7	000-255	<b>Magenta</b> 0%→100%
8	000-255	<b>Yellow</b> 0%→100%
9	000-255	<b>CTO</b> 0%→100%
10	000-009 010-018 019-027 028-036 037-045 046-063 064-127 128-189 190-193 194-255	<b>Color 1</b> Open Color1 Color2 Color3 Color4 Color5 Color Index Rotate Fast to Slow Stop Rotate Slow to Fast
11	000-009 010-018 019-027 028-036 037-045 046-054 055-063 064-127 128-189 190-193 194-255	<b>Color 2</b> Open Color1 Color2 Color3 Color4 Color5 Color6 Color Index Rotate Fast to Slow Stop Rotate Slow to Fast
12	000-007	<b>CRI</b> Close

	008-255	Open
<b>13</b>	000-255	<b>Frost</b> 0%→100%
<b>14</b>	000-255	<b>Zoom</b> 72°→5°
<b>15</b>	000-007 008-015 016-131 132-139 140-181 182-189 190-231 232-239 240-247 248-255	<b>Strobe</b> Close Open Strobe Slow to Fast Open Fast Open Slow Close Open Fast Close Slow Open Open Random Strobe Open
<b>16</b>	000-255	<b>Dimmer</b> 0%→100%
<b>17</b>	000-255	<b>Dimmer Fine</b>
<b>18</b>	000-029 030-039 040-049 050-059 060-069 070-079 080-089 090-099 100-109 110-119 120-129 130-139 140-149 150-159 160-169 170-179 180-189 190-199 200-209 210-219 220-229 230-255	<b>Function</b> Null Dimmer Curve Square Law Dimmer Curve INV Square Law Dimmer Curve Linear Dimmer Curve S Soften Mode On Soften Mode Off Null LED Frequency Setting Enable LED Frequency Setting Disable Null Null Null Null Null Null Dimmer Speed Fast Dimmer Speed Smooth Reset All Reset Effect Reset Pan/Tilt Null

## **8. Error Information**

**Error codes are shown continuously in the display when the fixture fails and they will not disappear until the fixture is repaired.**

### **1. CPU-B/C/D/E/F/G Error**

Check whether the 485 (DATA) leads on the PCB board are installed in place or disconnected.

Check whether the related 485 (DATA) signal circuit on the PCB board is damaged.

### **2. Pan Reset Error**

Check whether the position of the pan where the magnet is installed falls off or is damaged.

Check whether there are obstacles in the pan operating range.

Check whether the Hall element on the pan is damaged.

Check whether the lead connecting the Hall element on the pan and the PCB board is in poor contact or disconnected.

Check whether the motor on the pan is damaged.

Check whether the related circuit of the motor drive board on the pan is damage.

### **3. Pan Encoder Error**

Check whether the encoder on the pan is damaged.

Check whether the lead connecting the encoder on the pan and the PCB board is in poor contact or disconnected.

### **4. Tilt Reset Error**

Check whether the position of the tilt where the magnet is installed falls off or is damaged.

Check whether there are obstacles in the tilt operating range.

Check whether the Hall element on the tilt is damaged.

Check whether the lead connecting the Hall element on the tilt and the PCB board is in poor contact or disconnected.

Check whether the motor on the tilt is damaged.

Check whether the related circuit of the motor drive board on the tilt is damage.

### **5. Tilt Encoder Error**

Check whether the encoder on the tilt is damaged.

Check whether the lead connecting the encoder on the tilt and the PCB board is in poor contact or disconnected.

## **6. LED Fan1/2/3/4/5/6/7/8/9/10 Start Error**

Check whether the fan is not running.

Check whether the fan leads are installed in place or disconnected.

Check whether the fan is damaged.

Check whether there are obstacles in the fan operating range.

## **7. LED Fan1/2/3/4/5/6/7/8/9/10 Stop Error**

Check whether the fan circuit on the motherboard breaks down.

Check whether the component is damaged.

## **8. Base Fan1/2/3/4 Start Error**

Check whether the fan is not running.

Check whether the fan leads are installed in place or disconnected.

Check whether the fan is damaged.

Check whether there are obstacles in the fan operating range.

## **9. Base Fan1/2/3/4 Stop Error**

Check whether the fan circuit on the motherboard breaks down.

Check whether the component is damaged.

## **10. Cyan Error**

Check whether the position of the cyan color wheel where the magnet is installed falls off or is damaged.

Check whether there are obstacles in the cyan color wheel operating range.

Check whether the Hall element on the cyan color wheel is damaged.

Check whether the lead connecting the Hall element on the cyan color wheel and the PCB board is in poor contact or disconnected.

Check whether the motor on the cyan color wheel is damaged.

Check whether the related circuit of the motor drive board on the cyan color wheel is damaged.

## **11. Magenta Error**

Check whether the position of the magenta color wheel where the magnet is installed falls off or is damaged.

Check whether there are obstacles in the magenta color wheel operating range.

Check whether the Hall element on the magenta color wheel is damaged.

Check whether the lead connecting the Hall element on the magenta color wheel and the PCB board is in poor contact or disconnected.



Check whether the motor on the magenta color wheel is damaged.

Check whether the related circuit of the motor drive board on the magenta color wheel is damage.

## **12. Yellow Error**

Check whether the position of the yellow color wheel where the magnet is installed falls off or is damaged.

Check whether there are obstacles in the yellow color wheel operating range.

Check whether the Hall element on the yellow color wheel is damaged.

Check whether the lead connecting the Hall element on the yellow color wheel and the PCB board is in poor contact or disconnected.

Check whether the motor on the yellow color wheel is damaged.

Check whether the related circuit of the motor drive board on the yellow color wheel is damage.

## **13. CTO Error**

Check whether the position of the cto where the magnet is installed falls off or is damaged.

Check whether there are obstacles in the cto operating range.

Check whether the Hall element on the cto is damaged.

Check whether the lead connecting the Hall element on the cto and the PCB board is in poor contact or disconnected.

Check whether the motor on the cto is damaged.

Check whether the related circuit of the motor drive board on the cto is damage.

## **14. Color1/2 Error**

Check whether the position of the color wheel1/2 where the magnet is installed falls off or is damaged.

Check whether there are obstacles in the color wheel1/2 operating range.

Check whether the Hall element on the color wheel1/2 is damaged.

Check whether the lead connecting the Hall element on the color wheel1/2 and the PCB board is in poor contact or disconnected.

Check whether the motor on the color wheel1/2 is damaged.

Check whether the related circuit of the motor drive board on the color wheel1/2 is damage.

## 15. Zoom Error

Check whether the position of the zoom where the magnet is installed falls off or is damaged.

Check whether there are obstacles in the zoom operating range.

Check whether the Hall element on the zoom is damaged.

Check whether the lead connecting the Hall element on the zoom and the PCB board is in poor contact or disconnected.

Check whether the motor on the zoom is damaged.

Check whether the related circuit of the motor drive board on the zoom is damage.

## 16. Blade Reset Error

Check whether the position of the blade where the magnet is installed falls off or is damaged.

Check whether there are obstacles in the blade operating range.

Check whether the Hall element on the blade is damaged.

Check whether the lead connecting the Hall element on the blade and the PCB board is in poor contact or disconnected.

Check whether the motor on the blade is damaged.

Check whether the related circuit of the motor drive board on the blade is damage.

## The position of each fan of the fixture:

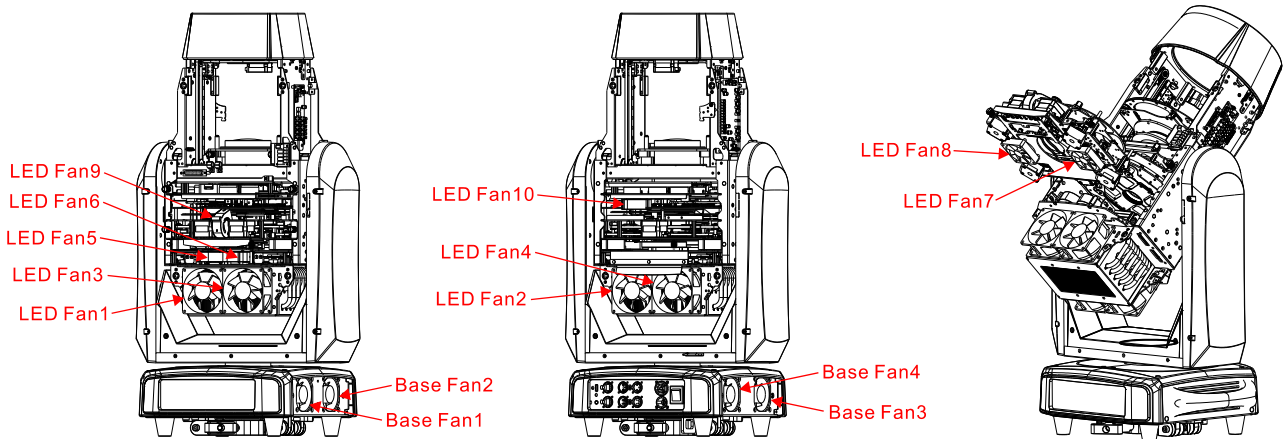

## 9. Troubleshooting

Following are a few common problems that may occur during operation. Here are some suggestions for troubleshooting:

### A. The unit does not work, no light and the fan does not work

1. Check the connected power.
2. Measure the voltage.
3. Check the power indicator to see whether it can be lit up or not.

### B. Not responding to the DMX controller

1. Check whether the DMX connectors and the DMX cables are connected correctly.
2. Check whether the DMX address is correctly set.
3. If the intermittent DMX signal problem occurs, check whether the XLR socket and the signal cable are well connected.
4. Try it with another DMX controller.
5. Check whether the DMX cables run near or alongside to the high-voltage cables, which may damage or interfere with the signal circuit.

### C. One of the channels is not working well

1. The stepper motor might be damaged or the cable connected to the PCB might be broken.
2. The motor's drive IC on the PCB might be out of condition.

## 10. Fixture Cleaning

It is absolutely essential that the fixture is kept clean to ensure the maximum light-output and allow the fixture to function reliably throughout its life. The fixture must be cleaned regularly to avoid dust, dirt and smoke-fluid residues building up on or within the fixture. The cleaning frequency depends on the application environment. Clean the fixture immediately if the dust enters it to avoid damage to the optical lens due to excessive dust.

- A soft lint-free cloth moistened with any good glass cleaning fluid is recommended, under no circumstances should solvents be used.
- Always dry the parts carefully.
- Clean the external optical lens at least every 20 days and the internal optical lens every 30 days.

## **Declaration of Conformity**

We declare that our products (lighting equipments) comply with the following specification and bears CE mark in accordance with the provision of the Electromagnetic Compatibility (EMC) Directive 2014/30/EU.

EN 55032: 2015; EN IEC 61000-3-2: 2019;  
EN 61000-3-3: 2013+A1: 2019; EN 55035: 2017.

**&**

## **Harmonized Standard**

EN 60598-1: 2015+A1: 2018; EN 60598-2-17: 2018;  
EN 62493: 2015.

Safety of household and similar electrical appliances  
Part 1: General requirements and tests

## **Certifications**

cETLus Approved (Control #5000057)

# **Innovation, Quality, Performance**